

# Ионекс

Тольятти: (8482) 25-82-40, (8482) 25-82-85, (927) 775-49-65, (906) 128-12-68, [tlt@ionexedm.ru](mailto:tlt@ionexedm.ru)

Москва: (499) 782-61-17, (916) 627-56-24, (926) 300-12-42, [msk@ionexedm.ru](mailto:msk@ionexedm.ru)

Томск: (3822) 23-16-80, (909) 543-16-80, [tomsk@ionexedm.ru](mailto:tomsk@ionexedm.ru)

[www.ionexedm.ru](http://www.ionexedm.ru)

Reference system for wire EDM machining.  
The standard range.

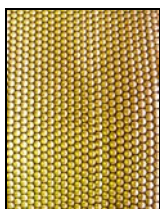
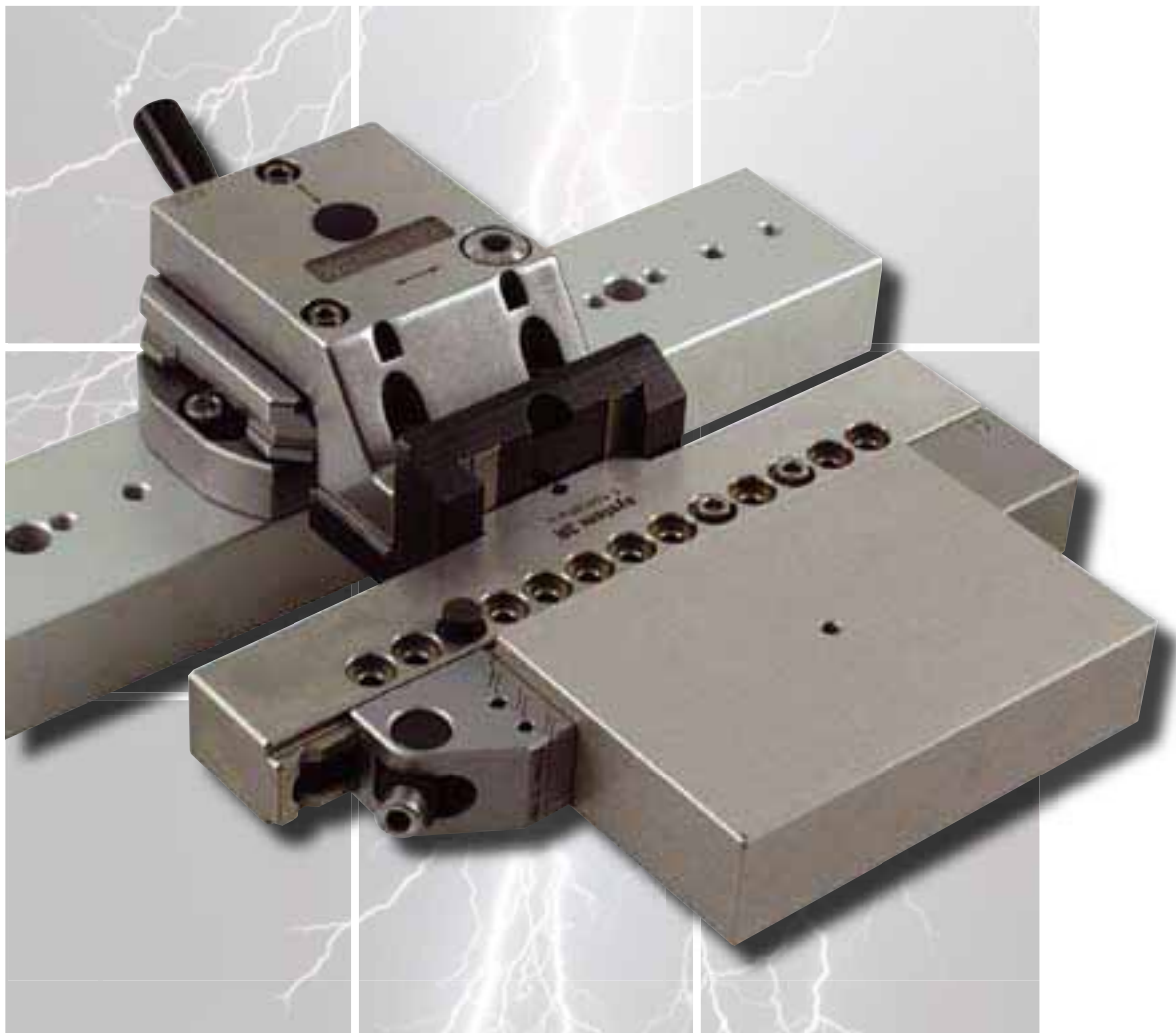

# Ионекс

Тольятти: (8482) 25-82-40, (8482) 25-82-85, (927) 775-49-65, (906) 128-12-68, [tlt@ionexedm.ru](mailto:tlt@ionexedm.ru)

Москва: (499) 782-61-17, (916) 627-56-24, (926) 300-12-42, [msk@ionexedm.ru](mailto:msk@ionexedm.ru)

Томск: (3822) 23-16-80, (909) 543-16-80, [tomsk@ionexedm.ru](mailto:tomsk@ionexedm.ru)

[www.ionexedm.ru](http://www.ionexedm.ru)

## A CHANGING WORLD

Our world is constantly changing and so is the manufacturing industry. The catalogue you are holding is one result of the merger of System 3R and Mecatool.

Today the entire joint product range is being developed, made and marketed under the System 3R brand. But there's no need to worry about your existing equipment, since System 3R will make sure that it can be integrated into the new product range.

The catalogue has two main sections – an orange section for customers who traditionally use wire EDM products from System 3R, and a blue section which is mainly for users of wire EDM accessories which used to be made by Mecatool. In both sections you will find adapter elements that give you free access to the entire product range, regardless of which system you used before.

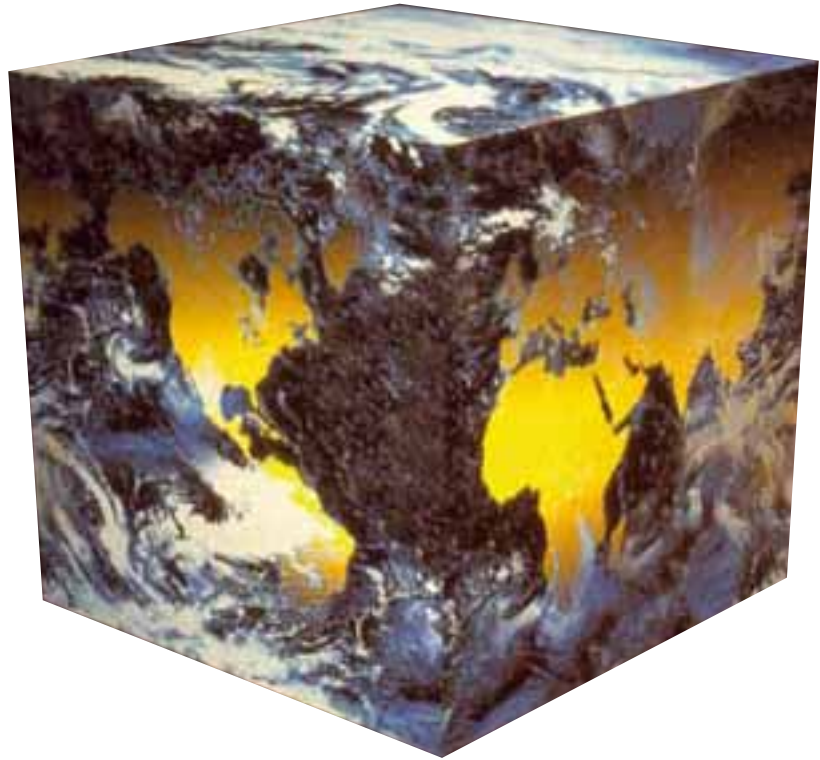

*Dimensions and weights stated in the product boxes are not normative unless this is expressly stated.*

✓ A green tick in the product boxes indicates that the product will normally be shipped within two weeks, provided that it is in stock when the order is placed.



## **THREE STEPS TO SUCCESS**

The route to rational production in wire EDM machines can be summarised in three steps – mounting, reference system and automation.

### **STEP 3 – AUTOMATION**

With a reference system and a pneumatic chuck on the machine table, you have laid a firm foundation for the crucial step towards maximised machine utilisation – automation.

Add a pallet changer to your machine and you have created an automated production cell. A cell that can generate revenue 24 hours a day, weekdays and weekends, all year round!

### **STEP 2 – REFERENCE SYSTEM**

Once the problem of effective mounting of the workpiece in the machine has been solved, the next step is to minimise downtimes when retooling the machine.

Technical developments of the machines in recent years have resulted in significantly higher material removal rates. But you won't benefit from this potential if the machine is idle for lengthy, troublesome retooling. So the aim must be to minimise retooling times with the machine idle.

With a reference system you can prepare and preset the workpiece away from the machine, then lift it in and secure it in the machine – quickly and precisely – with minimised downtime and consequent better utilisation of machine capacity.

### **STEP 1 – MOUNTING**

First of all, the workpiece needs to be positioned and secured in the working area of the machine, preferably on the zero line, and with the risk of collision with the machine's wire guides reduced to a minimum. And so firmly that it can handle the high flushing pressures of modern machines.

# CONTENTS

|   |         |
|---|---------|
| Basic equipment, WEDM .....                           | page 6  |
| Basic equipment, Macro .....                          | page 8  |
| Mounting heads .....                                  | page 13 |
| Holders and vices for mounting in mounting heads..... | page 18 |
| Chuck adapters .....                                  | page 24 |
| Holders for mounting in chuck adapters.....           | page 28 |
| Adapter elements.....                                 | page 31 |
| 3Ruler ruler system.....                              | page 33 |
| 3P three-point mounting.....                          | page 37 |
| Presetting and inspection.....                        | page 38 |
| Rotating spindles and accessories .....               | page 41 |
| Basic equipment, ICS .....                            | page 42 |
| ICS Zeroline .....                                    | page 43 |
| ICS guide elements .....                              | page 48 |
| ICS vertical-guide elements & adaptations.....        | page 52 |
| Unimatic .....  | page 53 |
| Unimatic pallets.....                                 | page 56 |
| Unimatic twin pallet & frame .....                    | page 57 |
| Unimatic accessories.....                             | page 58 |
| ICS clamping elements.....                            | page 59 |
| ICS clamping elements A.....                          | page 60 |
| ICS clamping elements B.....                          | page 62 |
| ICS clamping elements C .....                         | page 65 |
| Unimatic clamping elements .....                      | page 66 |
| Electrode clamping systems Unimatic / ICS .....       | page 69 |
| System adapters.....                                  | page 70 |
| Unimatic presetting stations.....                     | page 71 |
| Specific solutions.....                               | page 72 |
| Frame systems .....                                   | page 73 |
| Accessories.....                                      | page 74 |
| Automation .....                                      | page 75 |
| Index.....  | page 78 |



## WEDM POSITIONS

the workpiece within the working area of the machine and on the machine's zero line. Whether the workpiece is rectangular or round, small or large, thin or thick, tall or short, it is clamped with minimal risk of collision. There are infinitely many possible combinations in the product range, the only limitation being the user's imagination.

Without doubt, System 3R offers the most comprehensive product range on the market. What's more, it also leads in terms of number of installations - world wide.

- ▶ Exceptional flexibility
- ▶ Accurately ground-in references
- ▶ Repeatable accuracy
- ▶ Double-sided parallel references
- ▶ Fits all machine tables with 25 or 50 mm pitch



## OVERVIEW OF THE WEDM SYSTEM

Basic equipment on the machine table

Reference elements

Mounting heads  
3Ruler  
3P

Holders and vices

**Reference element WEDM  
3R-200.XJ-X**

Reference elements for machines with zero-line table. The length (L), hole spacing (C) and hole edge spacing (B) of the hardened reference elements are matched to the machine in question.

*Note: When ordering, state machine make and type.*

- Supplied with end stops

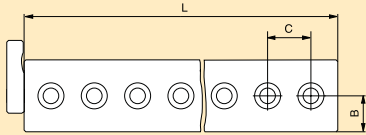

**✓ Reference element WEDM  
3R-200.1J-U**

Universal 150 mm reference element, with oval holes, for all machines that have M8 holes in the machine table, 30 to 40 mm from the edge of the table.

- Weight 0.4 kg

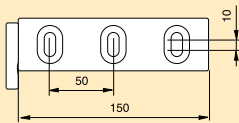

**✓ Reference stop  
3R-225**

Can be moved infinitely along the entire reference element.

- Hardened
- Weight 0.4 kg

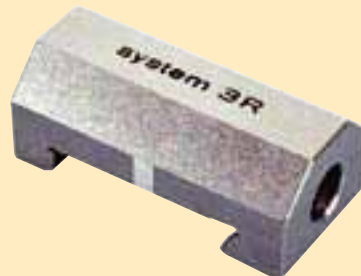

**Reference stop  
3R-225.1**

Mounts in any of the mounting holes in the reference element.

- Weight 0.15 kg

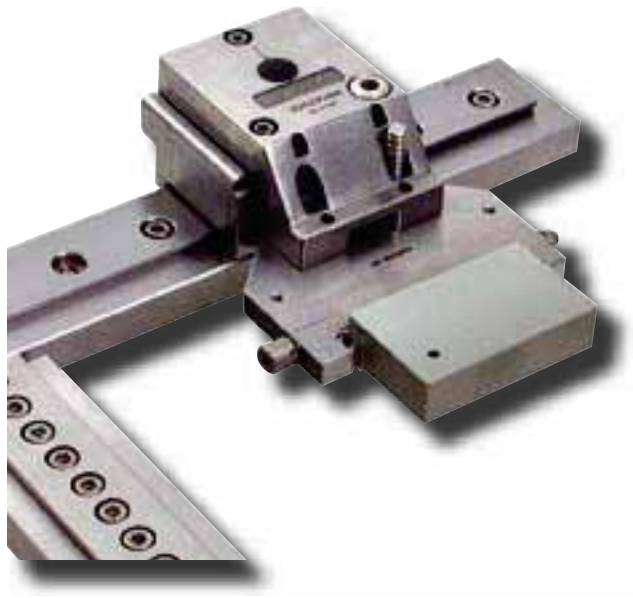

**WITH A MACROCHUCK**

as basic equipment on the machine table, you can interconnect all your machines to create a single system. Move the workpiece from the wire EDM machine to the grinding machine or the die-sinking machine without subsequent alignment – quickly and precisely.

If you choose a pneumatic Macro chuck, you can operate round-the-clock production if you wish.

- ▶ Allows fully automated production
- ▶ Links all your machines together
- ▶ Z-references with automatic air-blast cleaning
- ▶ X and Y references of cemented carbide
- ▶ Repetition accuracy 0.002 mm
- ▶ Turbo locking – enhanced clamping force

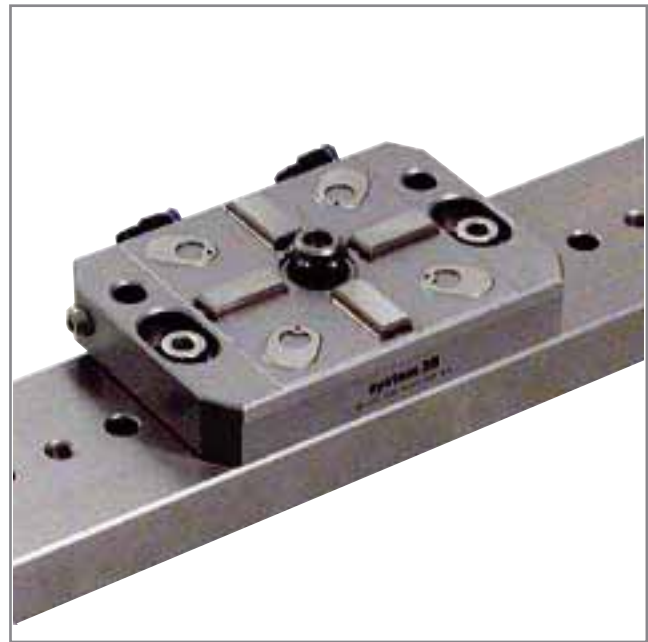

Note: The pneumatic chucks require an air pressure of  $6 \pm 1$  bar.

**RECOMMENDATIONS FOR LOADING IN MACRO CHUCKS**

**Table chucks with horizontal mounting of the workpiece**

| Article number | Max torque | Capacity<br>X=150 mm |
|----------------|------------|----------------------|
| 3R-602.27-1    | 18 Nm      | 12 kg                |
| 3R-602.10      | 22,5 Nm    | 15 kg                |
| 3R-602.10HP    | 30 Nm      | 20 kg                |
| 3R-602.27      | 30 Nm      | 20 kg                |
| 3R-602.26      | 30 Nm      | 20 kg                |
| 3R-602.12HP    | 45 Nm      | 30 kg                |

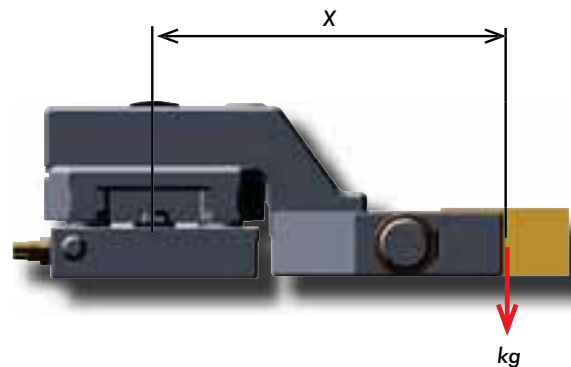

**Table chucks with vertical mounting of the workpiece.**

| Article number | Max torque | Capacity<br>X=100 mm |
|----------------|------------|----------------------|
| 3R-602.4.1     | 8 Nm       | 7-8 kg               |
| 3R-602.27-1    | 8 Nm       | 7-8 kg               |
| 3R-600.24-4RS  | 8 Nm       | 7-8 kg               |
| 3R-60.360-X    | 8 Nm       | 7-8 kg               |

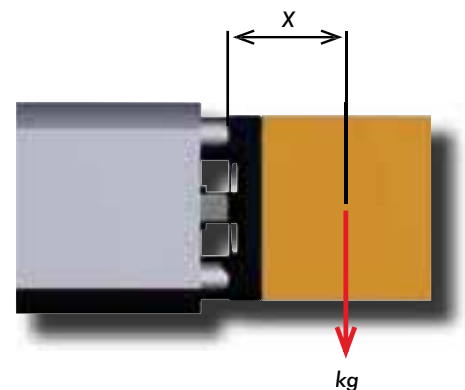

### OVERVIEW OF THE MACRO SYSTEM WITH HORIZONTAL MOUNTING

Basic equipment on the machine table

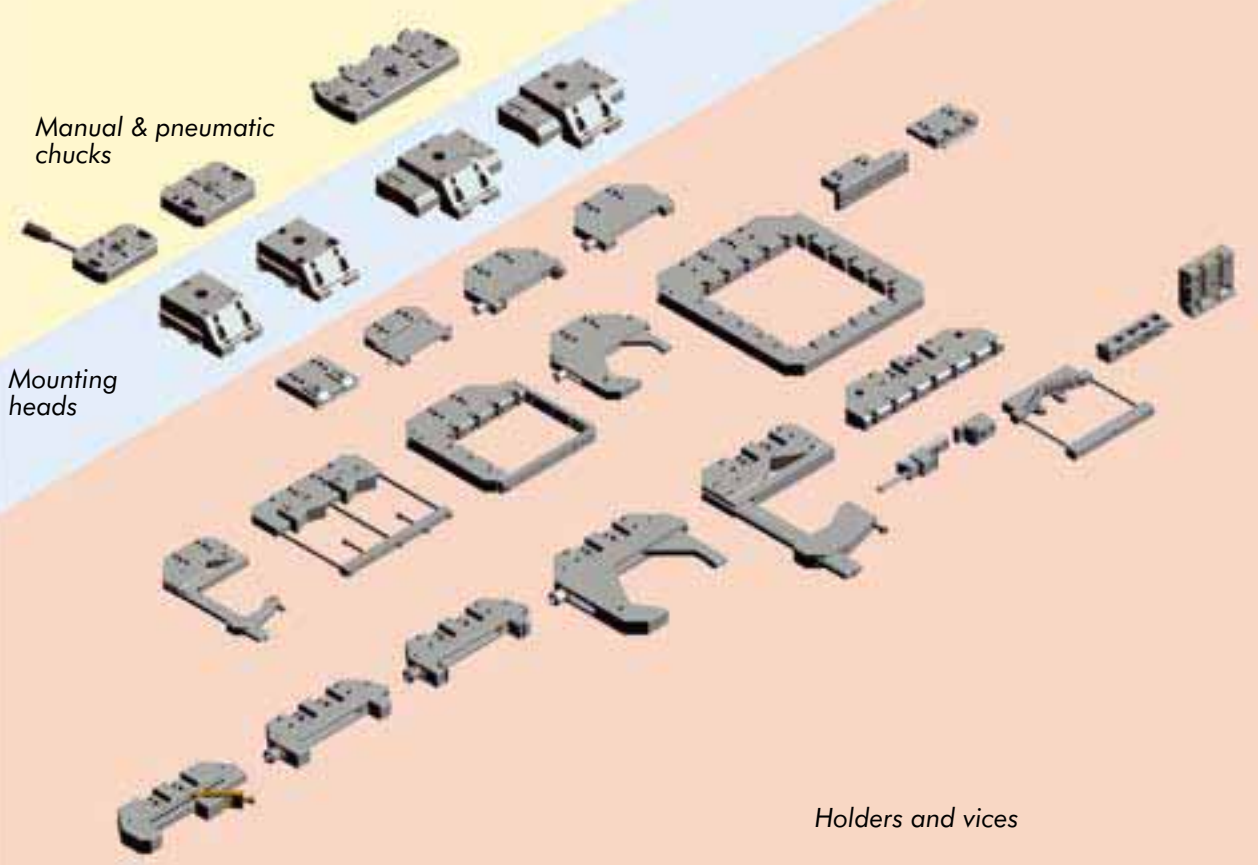

### OVERVIEW OF THE MACRO SYSTEM WITH VERTICAL MOUNTING

Basic equipment on the machine table

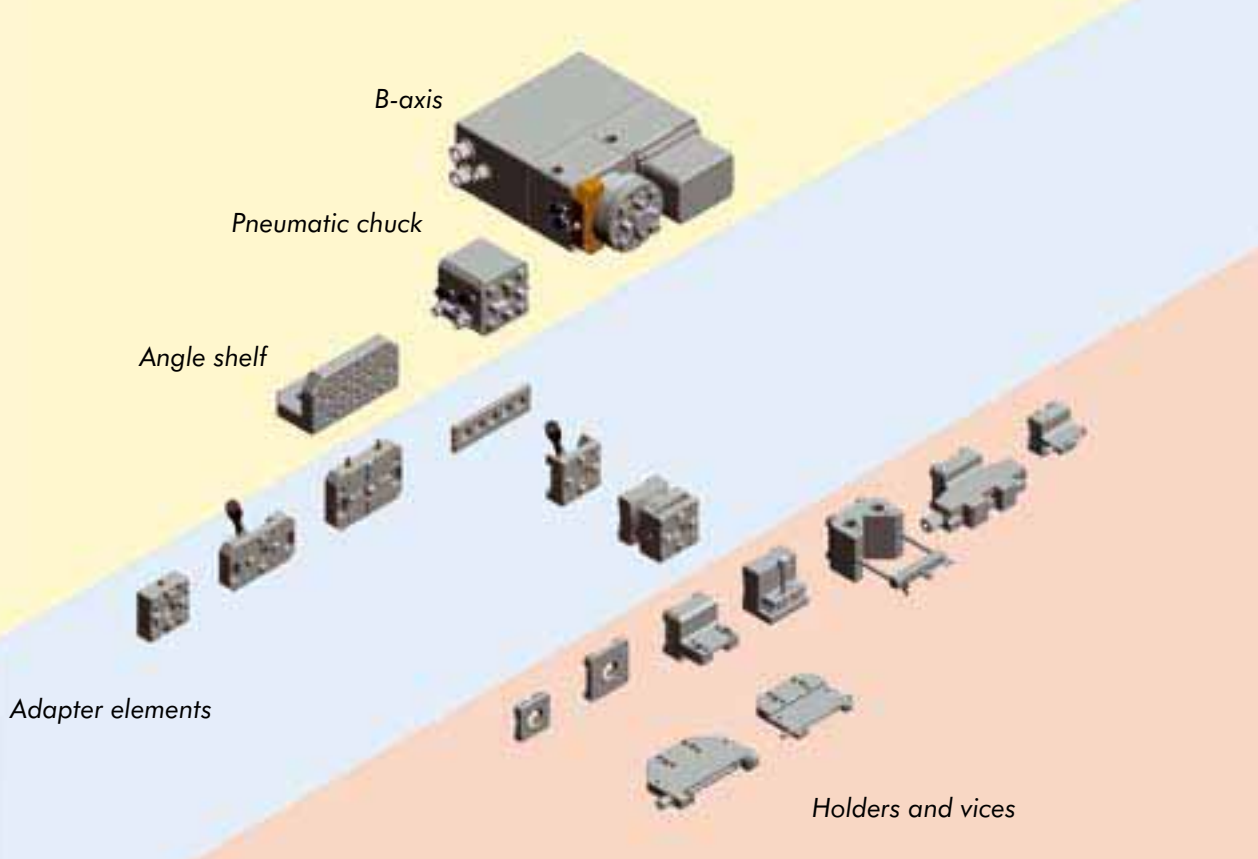



**Pneumatic chucks Macro**

Pneumatic chucks for Macro holders. Supplied with drawbar 3R-605.10 and protective cover.

- Fixed index positions 4x90°
- Air-blast cleaning of Z-references
- Weight 1.1 kg

✓ **3R-602.10**

- Clamping force 4500 N

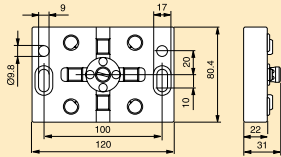

✓ **3R-602.10HP**

Note: When clamping Macro mounting heads, type HP only.

- Clamping force 7000 N

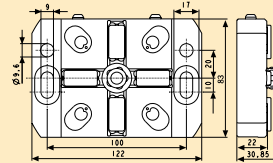

**Manual chuck for Macro**  
**3R-602.26**

Manual chuck for Macro holder. Supplied with drawbar 3R-605.26.

- Tightening torque 6 Nm
- Clamping force 6000 N
- Fixed index positions 4x90°
- Weight 1.1 kg

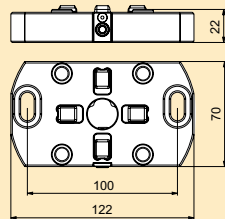
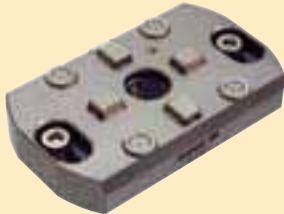

✓ **Manual chuck for Macro**  
**3R-602.27**

Manual chuck with lever for Macro holder. Supplied with drawbar 3R-605.27RS.

- Clamping force 6000 N
- Built-in latch function
- Fixed index positions 4x90°
- Weight 1.1 kg

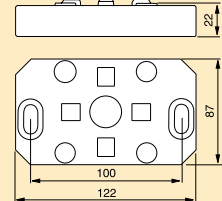

**Pneumatic chuck for MacroTwin**  
**3R-602.12HP**

Pneumatic chuck for Macro or MacroTwin. Horizontal mounting on the machine table. Supplied with two protective covers.

Note: When clamping Macro mounting heads, type HP only.

Note: On automatic changing with WorkPal – MacroTwin holders only.

- Required drawbar 3R-605.10 (two).
- Fixed index positions 4x90°
- Air-blast cleaning of the Z-references
- Clamping force 2x7000 N
- Weight 2.2 kg

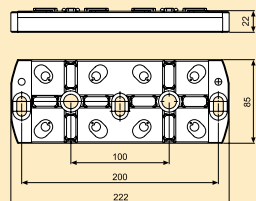

**Pneumatic chuck for Macro**  
**3R-602.4.1**

Pneumatic chuck for Macro holder.

- Required drawbar 3R-605.1RS
- Clamping force 6000 N
- Fixed index positions 4x90°
- Air-blast cleaning of Z-references
- Weight 3.7 kg

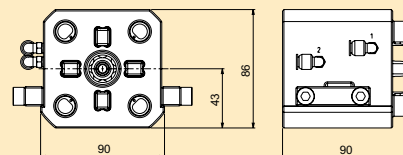

### Rotary Indexing Tables Macro

Compact Rotary Indexing Tables with pneumatic Macro chuck. Indexing 0-360° with smallest step 0.001°. Air connections for open/close, as well as turbo-locking/air-blast cleaning.

- Required drawbar 3R-605.1RS
- Rust-resistant
- Indexing accuracy  $\pm 0.003^\circ$  without correction
- Speed range 0-10 rev/min
- Automatic air-blast cleaning of the Z-references
- Weight 18 kg

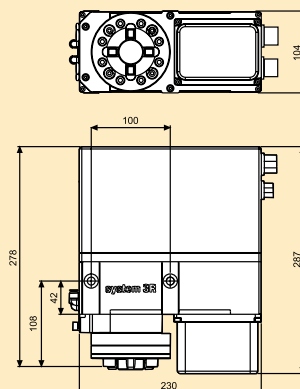

### Machine-adapted Rotary Indexing Table 3R-60.360X

Note: The units are controlled by the machine. The make and type of the machine must therefore be stated when ordering.

### Neutral Rotary Indexing Table 3R-60.360SA

Supplied with a separate control unit.

### Angle shelf 3R-201.5

Mounts directly on the machine table. For vertical mounting of a Macro chuck or short reference element in the machine. Supplied with M8 screw and washer (x3).

- Weight 4.2 kg

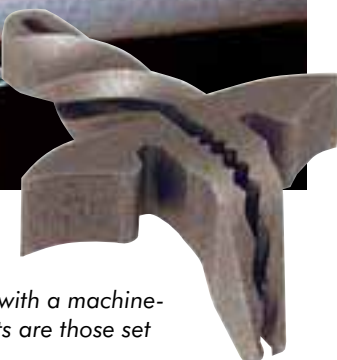
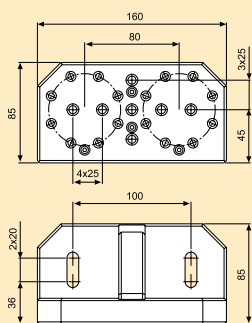

Complex part 18 mm long – with a machine-adapted B-axis, the only limits are those set by your imagination.

### Drawbars

#### ✓ 3R-605.1RS

- Drawbar  $\varnothing 20 \times 57.1$  mm with flushing hole  $\varnothing 7$  mm
- Rust-resistant
- Supplied singly



#### ✓ 3R-605.27RS

- Drawbar  $\varnothing 20 \times 27$  mm
- Rust-resistant
- Supplied singly



#### ✓ 3R-605.10

- Drawbar  $\varnothing 20 \times 13$  mm
- Rust-resistant
- Supplied singly



#### ✓ 3R-605.26

- Drawbar  $\varnothing 20 \times 32$  mm
- Rust-resistant
- Supplied singly



### Locking ring key 3R-605-GE

To lift the drawbar locking ring.

- Supplied in sets of two



**Actuator  
3R-611.60**

Unit for operating pneumatic chucks in B-axes. Two functions – open/closed with four seconds delay for air-blast cleaning.



**✓ Actuator  
3R-611.46**

Unit for operation of pneumatic chucks Three functions – open/neutral/closed.



**✓ Actuator  
3R-611.4**

Unit for operation of pneumatic chucks Two functions – open/closed.



**✓ Insulating kit  
K-30266**

Insulating kit for 3R-602.10, 3R-602.10HP, 3R-602.26 and 3R-602.27.



**Spare parts kit  
3R-SSP014**

Spare parts kit including instructions for 3R-602.10.



**Spare parts kit  
3R-SSP044**

Spare parts kit including instructions for 3R-602.10HP.



## RAPID SETUP

is essential if you want to benefit from the material removal capacity and the accuracy offered by modern machines. However, faster machines with increased flushing pressure cause resonance and vibration. So in order to fully utilise the capability of the machines it is necessary to have stable tools and workpiece mountings.

- ▶ Setup done in seconds
- ▶ Gives maximum workpiece precision
- ▶ Utilises the machine capacity
- ▶ More stable than any other system
- ▶ Minimal vibration
- ▶ Minimises resonance

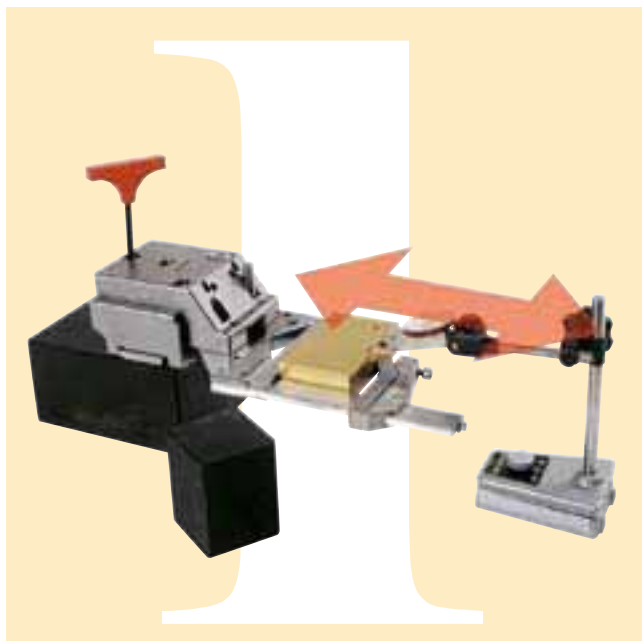

## PRE-SET IN THREE AXES

with System 3Rs levelling adapter. This can be done with an accuracy of thousandths of a millimetre!

The simple, directly measurable references of the levelling adapter mean that presetting can be done on an ordinary surface plate, using one of System 3R's presetting stones.

Preset away from the machine. Lift the preset "package" into place – levelling adapter, holder and workpiece – fix with a few simple manual operations and start the machine. Simple, quick and precise.

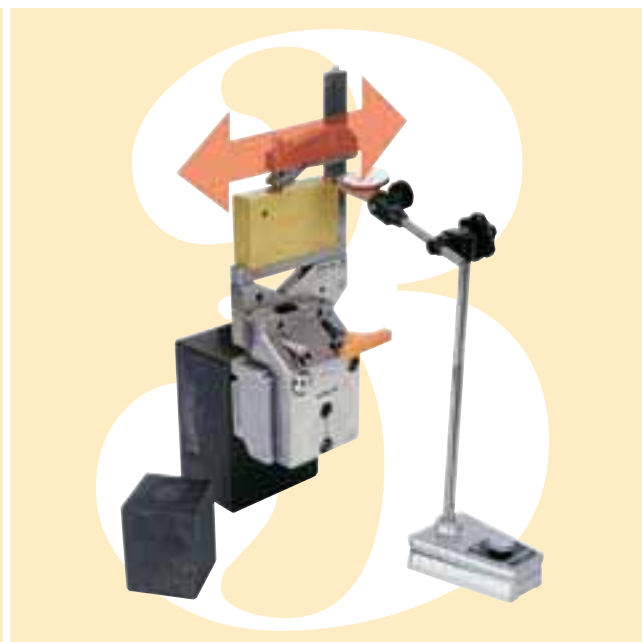
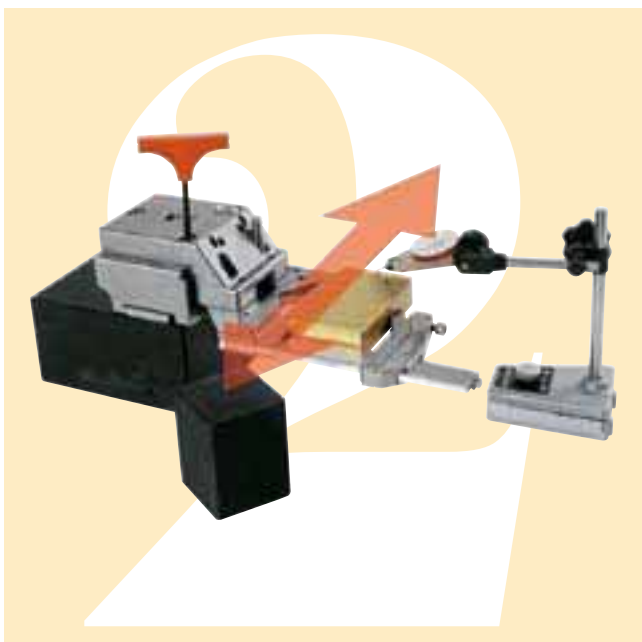

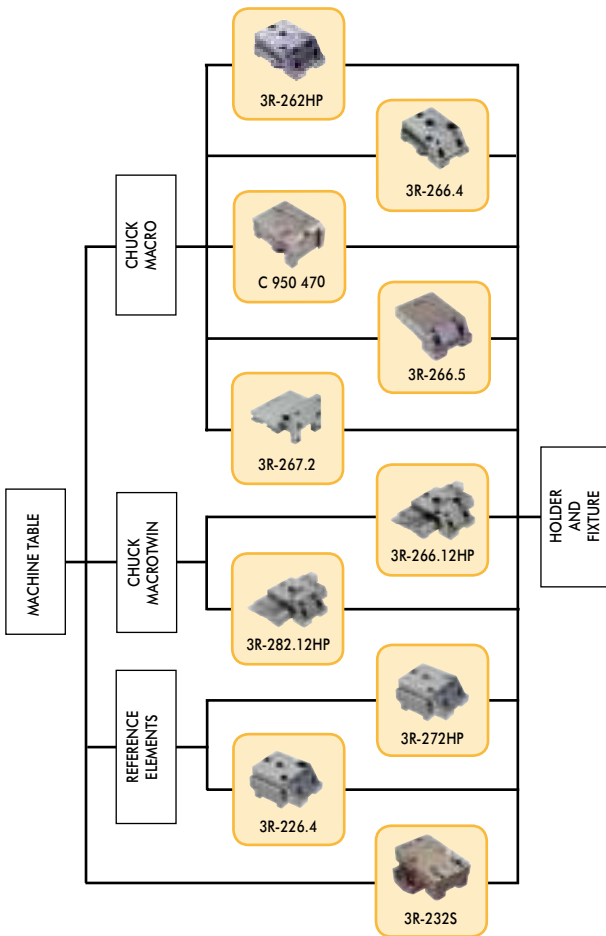

**✓ Levelling adapter WEDM  
3R-272HP**

For manual mounting of SuperVice, a holder or a fixture in the WEDM system.

*Note: All holders including HP can be mounted.*

*Note: Also fits the ICS system if the clamping jaw (17850-00) is changed.*

- Adjustable in three axes
- Supplied without drawbar
- Recommended maximum load 15 kg
- Weight 1.4 kg

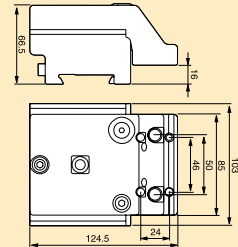

**Fixed mounting head WEDM  
3R-226.4**

For manual mounting of SuperVice, a holder or a fixture in the WEDM system.

*Note: All holders including HP can be mounted.*

*Note: Also fits the ICS system if the clamping jaw (17850-00) is changed.*

- Recommended maximum load 15 kg
- Weight 1.4 kg

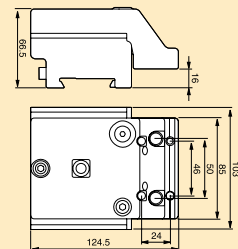

**✓ Levelling adapter Macro  
3R-262HP**

For mounting SuperVice, a holder or a fixture in the Macro system.

*Note: All holders including HP can be mounted.*

- Adjustable in three axes
- Supplied without drawbar
- Adapted for automatic changing
- Ready for code carrier
- Recommended maximum load 15 kg
- Weight 2.4 kg

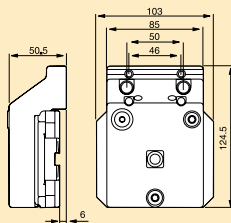

**✓ Fixed mounting head Macro  
3R-266.4**

For manual mounting of SuperVice, a holder or a fixture in the Macro system.

*Note: All holders including HP can be mounted.*

- Adapted for automatic changing
- Ready for code carrier
- Supplied without drawbar
- Recommended maximum load 15 kg
- Weight 1.4 kg.

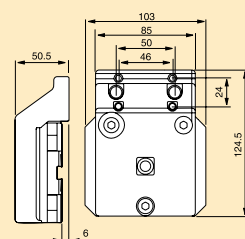

### Fixed mounting head, Macro 3R-266.5

For mounting SuperVice, a holder or a fixture in the Macro system.

*Note: All holders including HP can be mounted.*

- Can be adapted to automatic changing with 3R-WP1
- Ready for code carrier
- Supplied without drawbar
- Recommended maximum load 15 kg
- Weight 2.4 kg



### Levelling adapter Magnum MacroTwin 3R-282.12HP

For mounting Magnum holders in the MacroTwin system.

*Note: All holders including HP can be mounted.*

- Adjustable in three axes
- Can be adapted to automatic changing with 3R-W12-S
- Supplied with drawbar 3R-605.10 x2
- Ready for code carrier
- Recommended maximum load 15 kg
- Weight 3.1 kg

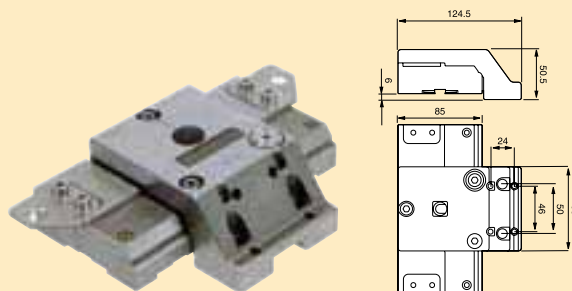

### Fixed mounting head Magnum MacroTwin 3R-266.12HP

For manual mounting of Magnum holders in the MacroTwin system.

*Note: All holders including HP can be mounted.*

- Can be adapted to automatic changing with 3R-W12-S
- Supplied with drawbar 3R-605.10 x2
- Ready for code carrier
- Recommended maximum load 15 kg
- Weight 3.1 kg

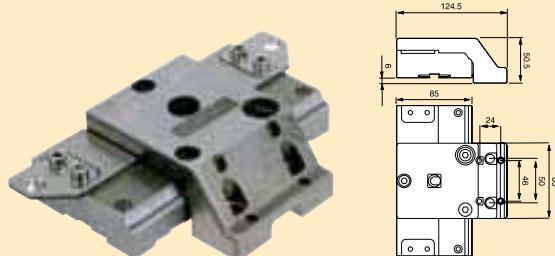

### Unimacro Adjusting pallet C 950 470

For manual mounting of Unimatic holders and Unimatic clamping elements in the Macro system. Adjusting pallet with dovetail guide adaptation.

- Adjustment range  $\pm 0.2$  mm for all three axes
- Functional height 59 mm, Unimatic pallet placed onto Macro chuck
- Ready for code carrier
- Weight 2.7 kg

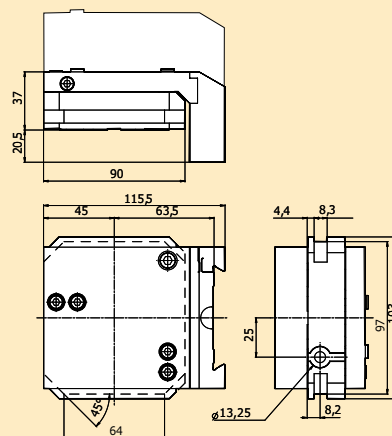



### Angled fixed mounting head Macro 3R-267.2

Fixed 90-degree head with 3Refix holes for mounting fixtures in the Macro system.

- 3Refix Ø10 mm
- Adapted for automatic changing
- Ready for code carrier
- Supplied without drawbar
- Recommended maximum load 7 kg
- Weight 3 kg

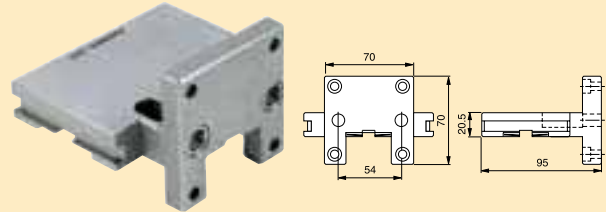

### ✓ Levelling adapter 3R-232S

For mounting SuperVice, a holder or a fixture directly on the machine table.

*Note: All holders including HP can be mounted.*

- Adjustable in three axes when clamped in the machine.
- Recommended maximum load 15 kg
- Weight 3.8 kg

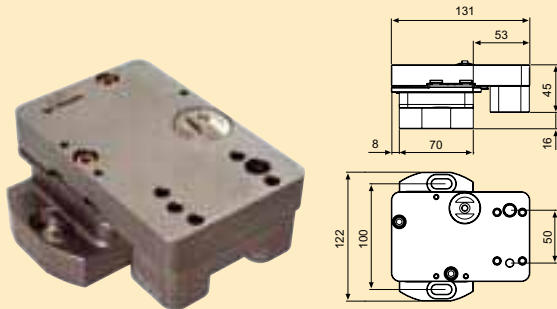

### Adapters

For mounting ICS holders in WEDM, Macro and MacroTwin mounting heads.

#### C 457 940

- ICS A

#### C 457 960

- ICS B

#### C 457 980

- ICS C



### Adapter C 950 280

For mounting Unimatic holders in WEDM, Macro and MacroTwin mounting heads.

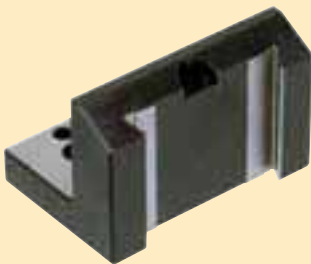

### User kit 3R-242HP

|           |                      |    |
|-----------|----------------------|----|
| 3R-225    | Reference stop       | x1 |
| 3R-272HP  | Levelling adapter HP | x1 |
| 3R-292.3  | SuperVice <100 mm    | x1 |
| 3R-293.3  | SuperVice Ø8-90 mm   | x1 |
| 3R-294.3  | Vice <100 mm         | x1 |
| 3R-914.07 | Torque wrench, 7Nm   | x1 |
| 3R-333-03 | Allen key, 3 mm      | x1 |
| 3R-333.05 | Allen key, 5 mm      | x1 |

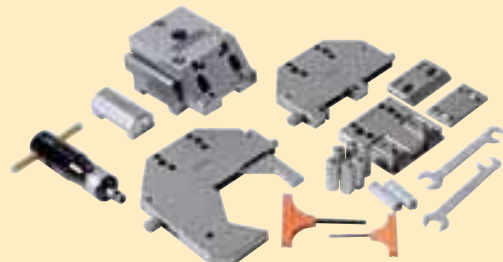

**User kit  
3R-242.82HP**

|             |                      |    |
|-------------|----------------------|----|
| 3R-239.1    | Ruler vice           | x1 |
| 3R-272HP    | Levelling adapter HP | x1 |
| 3R-292.66HP | Magnum Holder HP     | x1 |



**User kit  
3R-242S-1**

|           |                   |    |
|-----------|-------------------|----|
| 3R-232S   | Levelling adapter | x1 |
| 3R-292.3S | Universal holder  | x1 |
| 3R-333.03 | Allen key, 3 mm   | x1 |
| 3R-333.05 | Allen key, 5 mm   | x1 |

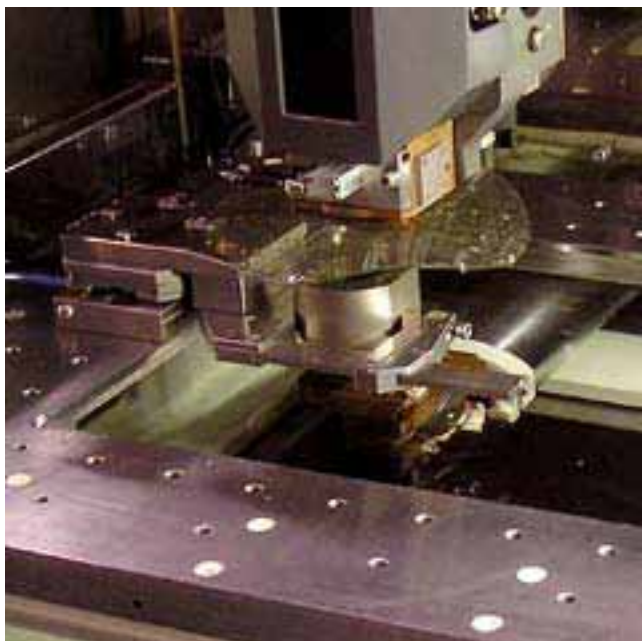
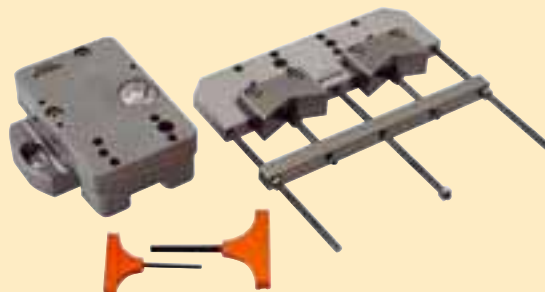

**User kit  
3R-242S-2**

|           |                   |    |
|-----------|-------------------|----|
| 3R-232S   | Levelling adapter | x1 |
| 3R-292.6S | SuperVice Magnum  | x1 |
| 3R-333.03 | Allen key, 3 mm   | x1 |
| 3R-333.05 | Allen key, 5 mm   | x1 |



**User kit  
3R-242S-3**

|           |                   |    |
|-----------|-------------------|----|
| 3R-232    | Levelling adapter | x1 |
| 3R-293.33 | Universal holder  | x1 |
| 3R-333.03 | Allen key, 3 mm   | x1 |
| 3R-333.05 | Allen key, 5 mm   | x1 |

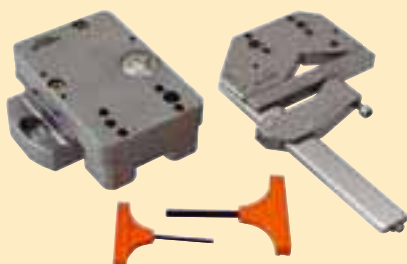

**User kit  
3R-242S-4**

|            |                         |    |
|------------|-------------------------|----|
| 3R-602.2   | Manual chuck            | x1 |
| 3R-262HP   | Levelling adapter Macro | x1 |
| 3R-292.6S  | SuperVice Magnum        | x1 |
| 3R-605.26  | Drawbar                 | x1 |
| 3R-333.05  | Allen key, 5 mm         | x1 |
| 45600-N03  | Allen key, 3 mm         | x1 |
| 45600-N041 | Allen key, 6 mm         | x1 |





**SUPERVICE**

solves setting-up problems for the most frequently occurring sizes of workpiece – small to medium-sized.

The high repetition accuracy not only allows presetting and fast setup; it also provides a solid foundation for rational series production. The springback is minimal and resonance damping is significant. Add this together and you have a very firm grip on production. SuperVice delivers more than others dare to promise.

- ▶ The low profile gives clearance from the upper and lower wire guides
- ▶ High clamping force.

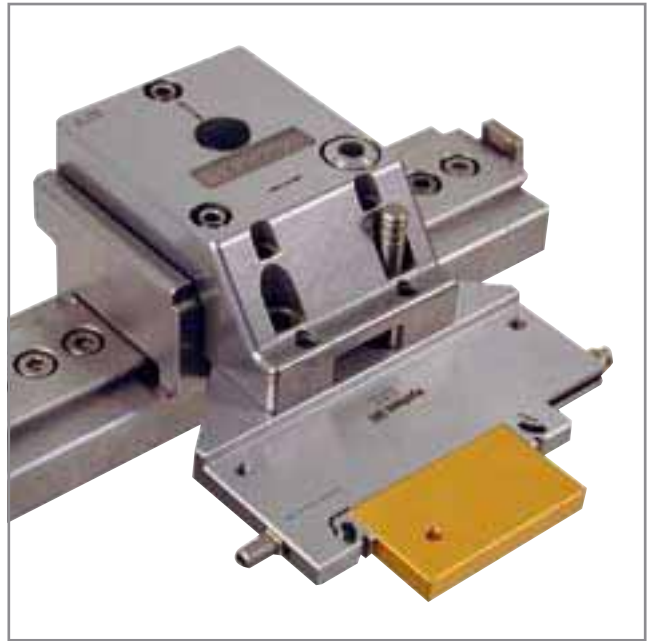

*The unique, patented asymmetric design of the locking jaws gives extremely high locking force and enhances the contact between the workpiece and the reference surface at the same time.*

| Article number | Recommended maximum torque | Maximum workpiece weight X* = 50 mm | Maximum workpiece weight X* = 100 mm | Torque generated in chuck coupling |
|----------------|----------------------------|-------------------------------------|--------------------------------------|------------------------------------|
| 3R-292.1       | 3.0 Nm                     | 6 kg                                | 3.0 kg                               | 10.8 Nm                            |
| 3R-292.2       | 3.5 Nm                     | 7 kg                                | 3.5 kg                               | 12.4 Nm                            |
| 3R-292.3       | 8.0 Nm                     | 16 kg                               | 8.0 kg                               | 28.6 Nm                            |
| 3R-292.31      | 5.5 Nm                     | 11 kg                               | 5.5 kg                               | 20.0 Nm                            |
| 3R-292.6HP     | 20.0 Nm                    | 40 kg                               | 20.0 kg                              | 63.0 Nm                            |
| 3R-292.61HP    | 13.0 Nm                    | 26 kg                               | 13.0 kg                              | 39.6 Nm                            |
| 3R-292.6S      | 9.0 Nm                     | 18 kg                               | 9.0 kg                               | 30.4 Nm                            |
| 3R-294.1       | 2.5 Nm                     | 5 kg                                | 2.5 kg                               | 9.3 Nm                             |
| 3R-294.2       | 5.0 Nm                     | 10 kg                               | 5.0 kg                               | 18.8 Nm                            |
| 3R-294.3       | 6.0 Nm                     | 12 kg                               | 6.0 kg                               | 20.4 Nm                            |

\*Centre of gravity of the workpiece with X mm overhang

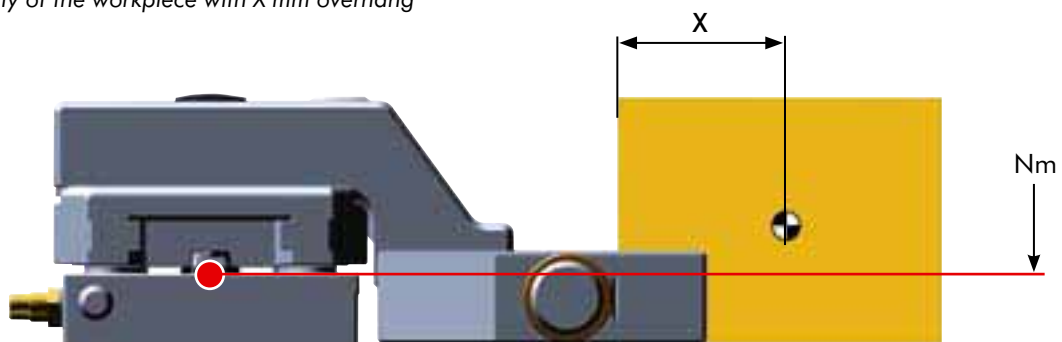

# HOLDERS AND VICES FOR MOUNTING IN MOUNTING HEADS

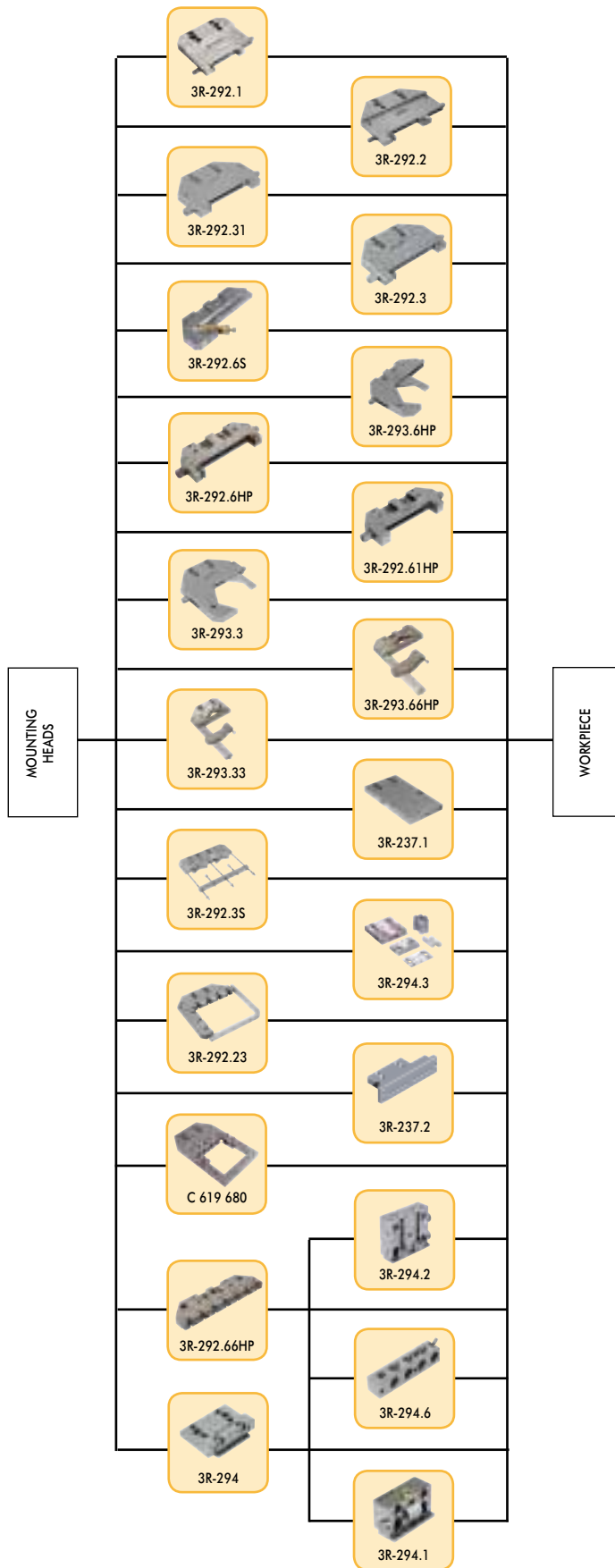

✓ **SuperVice**  
**3R-292.1**

For clamping rectangular workpieces up to 77 mm.

- Tightening torque 4 Nm
- Weight 0.6 kg

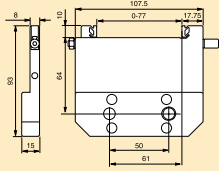

✓ **SuperVice**  
**3R-292.2**

For clamping rectangular workpieces up to 100 mm.

- Tightening torque 3 Nm
- Weight 0.9 kg

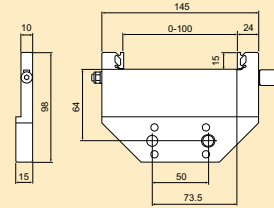

✓ **SuperVice**  
**3R-292.3**

For clamping rectangular workpieces up to 100 mm.

- Tightening torque 7 Nm
- Weight 1.1 kg

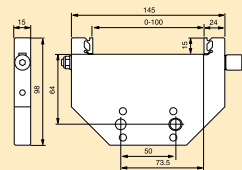

✓ **SuperVice**  
**3R-292.31**

Vice with solid jaws for clamping rectangular workpieces up to 100 mm.

- Tightening torque 7 Nm
- Weight 1.1 kg

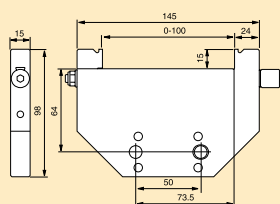

✓ **SuperVice Magnum**  
**3R-292.6HP**

Vice for clamping rectangular workpieces up to 155 mm.

*Note: Mounts on HP, Magnum or MacroTwin levelling adapter.*

- Tightening torque 15 Nm
- Weight 2.8 kg

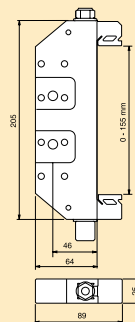

**SuperVice Magnum  
3R-292.61HP**

Vice with solid jaws for clamping rectangular workpieces up to 150 mm.

*Note: Mounts on HP, Magnum or MacroTwin levelling adapter.*

- Tightening torque 15 Nm
- Weight 2.8 kg

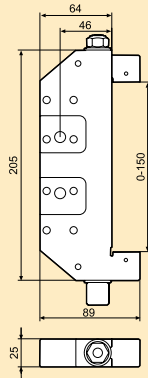

**SuperVice Magnum  
3R-292.6S**

Vice for clamping rectangular workpieces up to 150 mm.

*Note: Mounts on HP, Magnum or MacroTwin levelling adapter.*

- Tightening torque 10 Nm
- Weight 2.7 kg

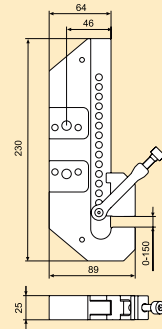

**✓ SuperVice  
3R-293.3**

Vice for clamping round workpieces 8-90 mm.

- Recommended maximum workpiece weight 7 kg
- Tightening torque 7 Nm
- Weight 1.7 kg

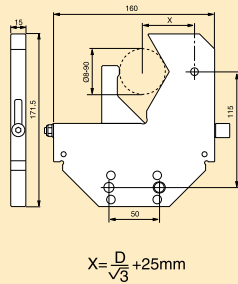

**✓ SuperVice Magnum  
3R-293.6HP**

Vice for clamping round workpieces 15-155 mm.

*Note: Mounts on HP, Magnum or MacroTwin levelling adapter.*

- Recommended maximum workpiece weight 12 kg
- Tightening torque 15 Nm
- Weight 4.5 kg

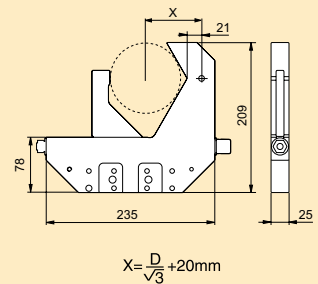

**✓ Universal holder  
3R-293.33**

Holder for round workpieces 8-100 mm, or rectangular workpieces up to 100 mm.

- Recommended maximum workpiece weight 7 kg.
- Tightening torque 3 Nm
- Weight 1.5 kg

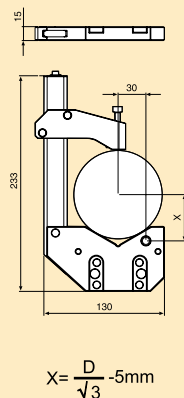

**Universal holder Magnum  
3R-293.66HP**

For round workpieces 15-150 mm diameter, or rectangular workpieces up to 150 mm.

*Note: Mounts on HP, Magnum or MacroTwin mounting head.*

- Recommended maximum workpiece weight 12 kg.
- Tightening torque 4 Nm
- Weight 4.2 kg.

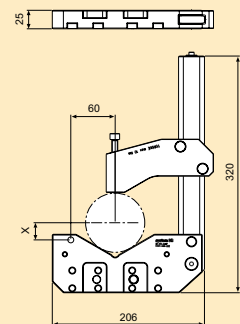

**Clamping frame  
C 619 680**

Carrier for flat round or cubic workpieces up to 80x80 mm.  
*Note: Mounts on HP, Magnum or MacroTwin levelling adapter.*

- Functional height 13 mm
- Clamping range round or cubic up to 80 mm / maximum workpiece height 12 mm
- Maximum workpiece weight 1.5 kg
- Maximum workpiece dimensions  $\varnothing$  80 mm or 80x80 mm
- Weight 0.9 kg

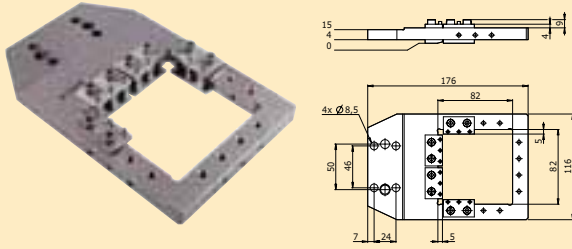

**✓ Clamping bar to clamping frame  
C 619 670**

Clamping bar to use with ICS clamping frame A C 619 680.

- Dimensions 88 x 20 x 26 mm
- Overall height 26 mm (incl. support lips and clamping lips)
- Weight 0.25 kg

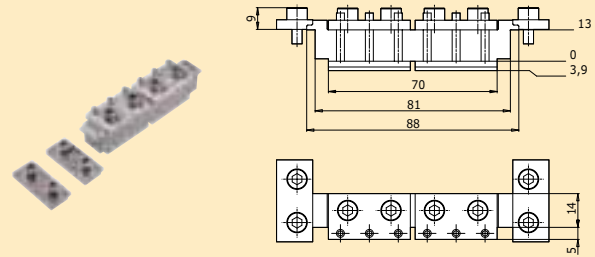

**Universal holder  
3R-292.3S**

Holder for round workpieces up to 90 mm, or rectangular workpieces 100x90 mm.

- Recommended maximum workpiece weight 7 kg.
- Tightening torque 4 Nm
- Weight 2.3 kg.

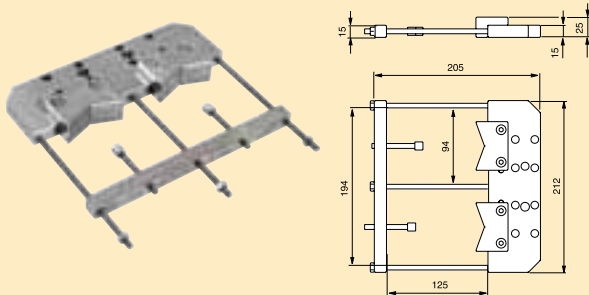

**Holder  
3R-237.1**

Stainless steel hardened "do-it-yourself" holder. With start hole for wire EDM of the required shape for clamping one or more workpieces.

- Recommended maximum weight 7 kg
- Weight 1.2 kg

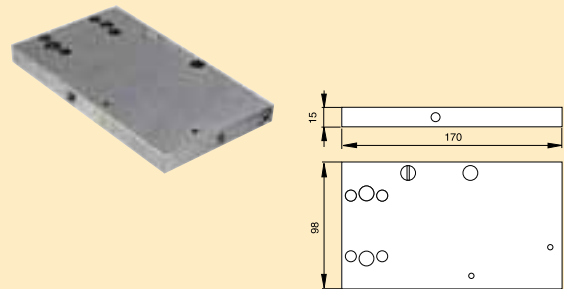

**✓ Vice  
3R-294.3**

For clamping workpieces up to 100 mm.

- Tightening torque 7 Nm
- Weight 0.7 kg

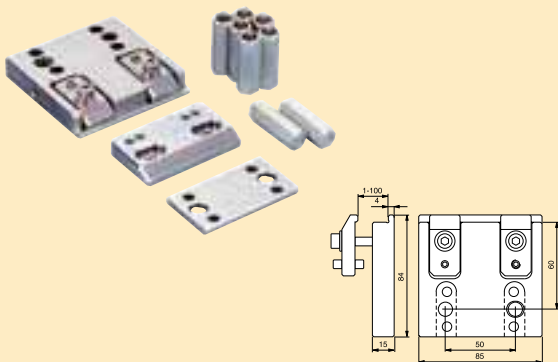

**Holder  
3R-237.2**

For fixture, workpiece or 3R-239.2, 3R-239.3, 3R-294.1, 3R-294.2, 3R-294.6 and 3R-402.1.

- Weight 0.6 kg

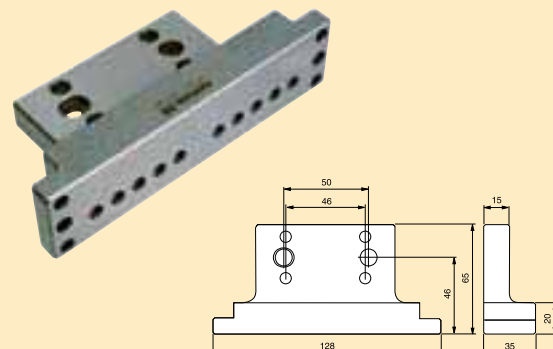

**Multiple holder  
3R-294.6**

For mounting four workpieces  $\varnothing 5-13$  mm at the same time. Mounts on 3R-237.2, 3R-294, 3R-292.66HP or a ruler in the 3Ruler system.

- Tightening torque 3 Nm
- Weight 0.6 kg

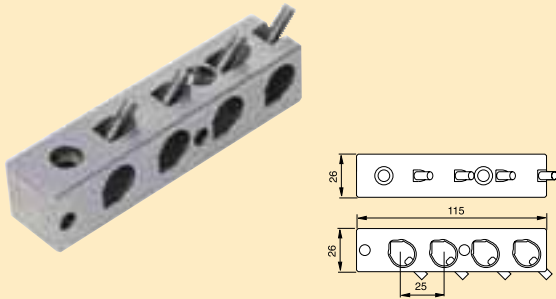

**✓ Holder Magnum  
3R-292.66HP**

Can be supplemented with 3Ruler accessories.

*Note: Mounts on an HP mounting head.*

- Weight 3 kg

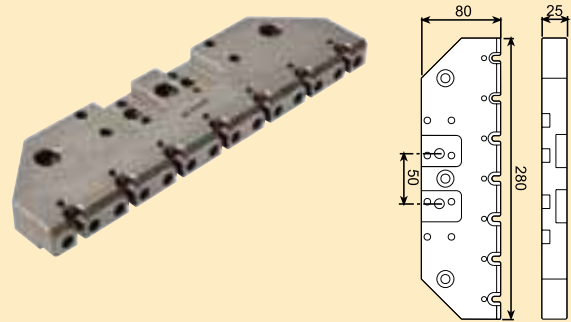

**Adapter  
3R-294**

For mounting 3R-294.1, 3R-294.2 and 3R-294.6 on a levelling adapter.

- Weight 0.6 kg

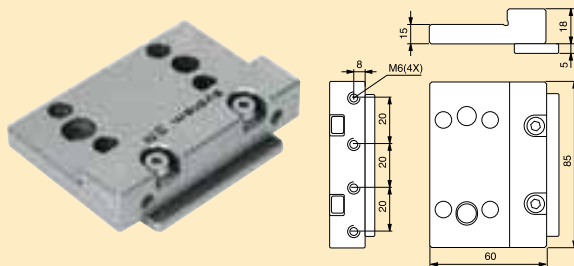

**Vice  
3R-294.1**

For clamping workpieces up to 17 mm. Mounts on 3R-237.2, 3R-294, 3R-292.66HP or rulers in the 3Ruler system.

- Tightening torque 3 Nm
- Weight 0.5 kg

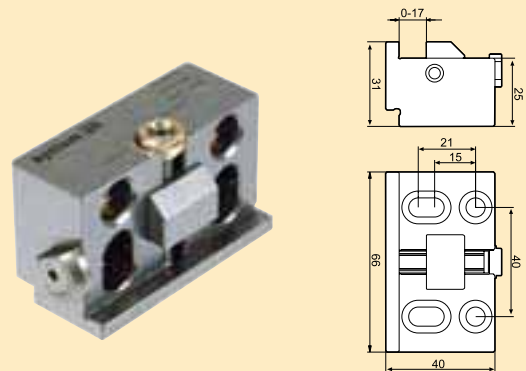

**Vice  
3R-294.2**

For clamping workpieces up to 50 mm. Mounts on 3R-237.2, 3R-294, 3R-292.66HP or a ruler in the 3Ruler system or Macropallet 54x54 mm.

- Tightening torque 3 Nm
- Weight 1.2 kg

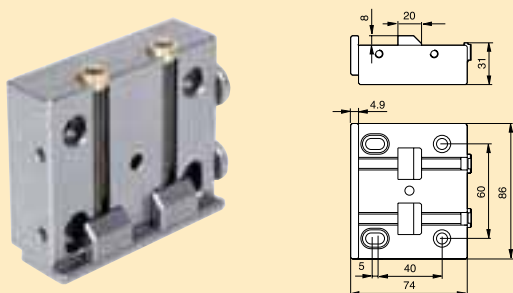

**Angled holder  
3R-292.23**

For clamping a workpiece or fixture on a mounting head. Can be supplemented with 3Ruler accessories.

- Weight 3 kg

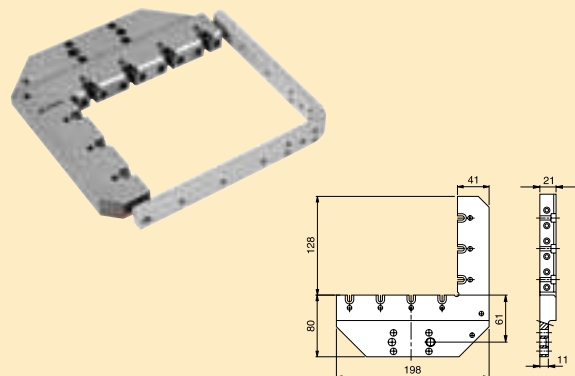

**A WIDE RANGE**

of chuck adapters for clamping workpieces on pallets in the Macro, MacroJunior and Mini systems. An ever-growing field of application is the manufacture of precision parts for the medical industry; another is the manufacture of electrodes for die-sinking EDM.

The chuck adapters can interconnect all your machines to form a single system. All chuck adapters are hardened and rust-resistant.

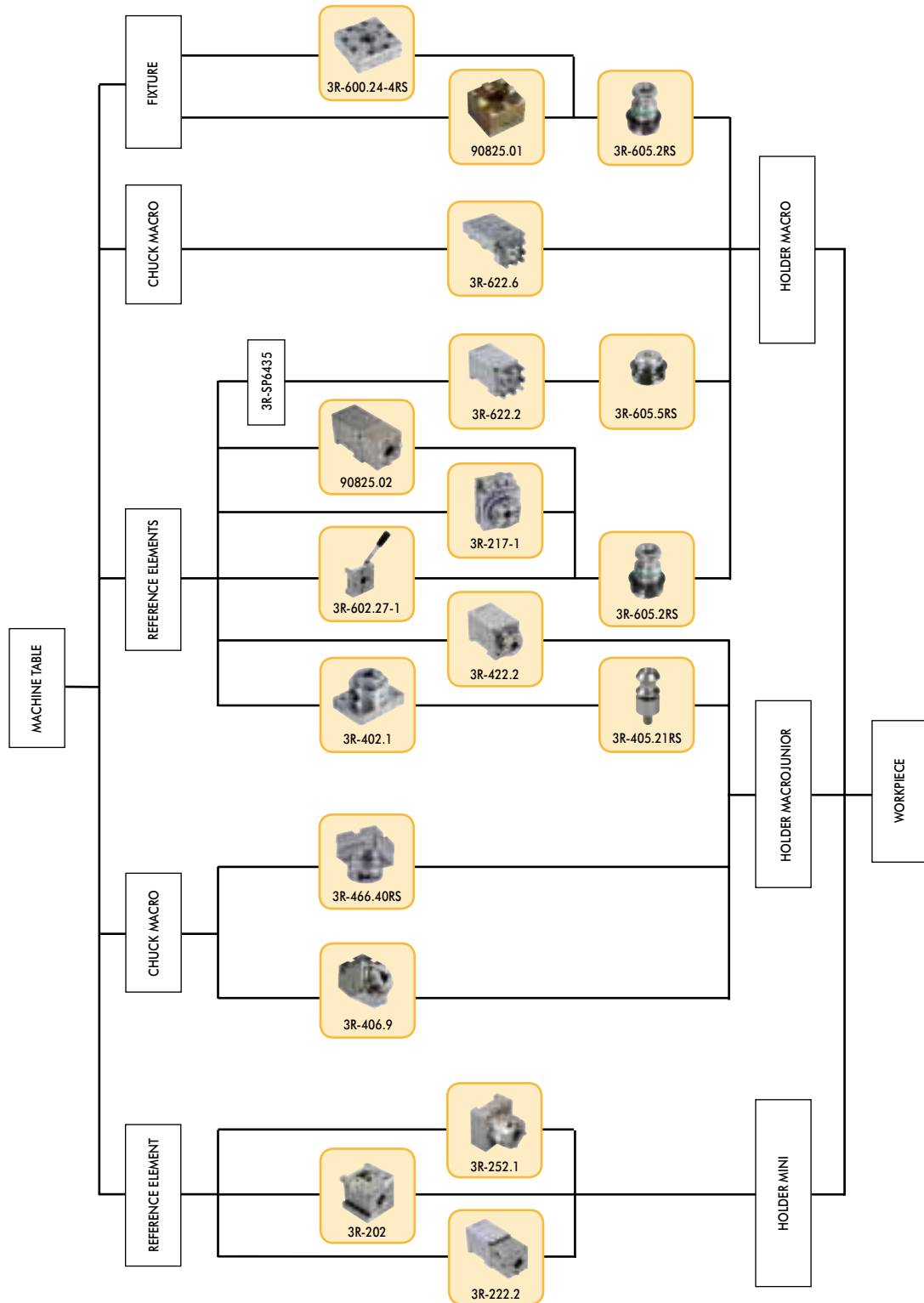

✓ **Manual chuck Macro**  
**3R-600.24-4RS**

Chuck for Macro holder. Mounts on a suitable fixture.

- Required drawbar 3R-605.2RS
- Fixed index positions 4x90°
- Weight 1 kg

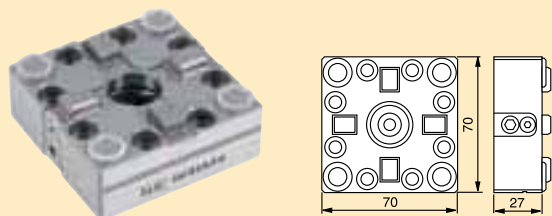

**Manual chuck Macro**  
**3R-602.27-1**

Chuck adapter with lever for Macro holder in the WEDM system. Supplied with drawbar.

*Note: When mounted on the reference element, the two clamping jaws must be tightened with the same torque, 4 Nm.*

- Required drawbar 3R-605.27
- Clamping force 6000 N
- Fixed index positions 4x90°
- Weight 1.1 kg

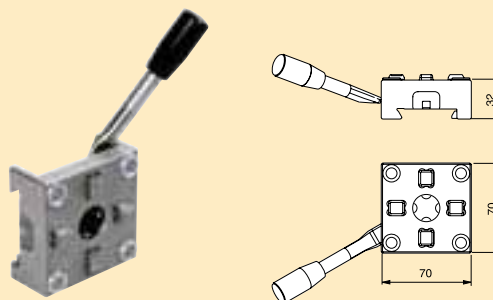

**Pneumatic chuck Macro**  
**90825.01**

Pneumatic built-in chucks for Macro holders.

- Required drawbar 3R-605.2RS
- Fixed index positions 4x90°
- Weight 0.8 kg

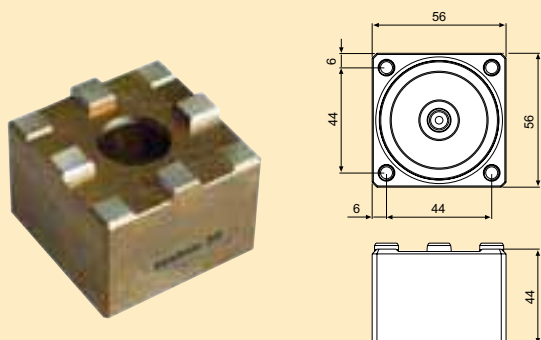

**Pneumatic chuck Macro**  
**90825.02**

Pneumatic chuck adapters for Macro holders in the WEDM system.

- Required drawbar 3R-605.2RS
- Fixed index positions 4x90°
- Weight 2 kg



**Manual chuck Macro**  
**3R-622.2**

Chuck adapter for Macro holders in the WEDM system.

- Supplied with drawbar 3R-605.5RS
- Fixed index positions 4x90°
- Weight 1.9 kg

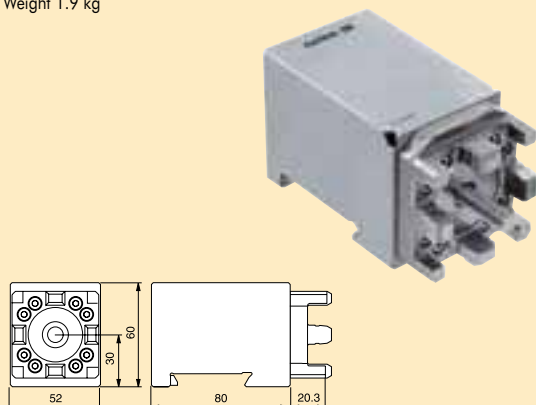

**Manual chuck Macro**  
**3R-622.6**

Chuck adapter for mounting Macro holders 90° in the Macro system.

- Supplied with drawbar 3R-605.5RS
- Fixed index positions 4x90°
- Ready for code carrier holder 3R-U30638
- Can be adapted to automatic changing with 3R-WP1
- Weight 2.3 kg

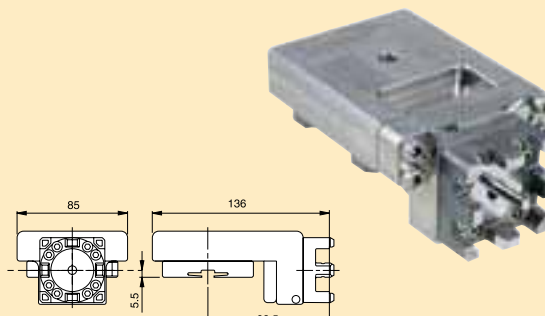



**3R-block Macro  
3R-217-1**

Manual block for Macro holder. Vertical or horizontal mounting on the machine table, or alternatively the WEDM system with the aid of 3R-SP6435.

- Required drawbar 3R-605.2RS
- Fixed index positions 24x15°
- Vernier scale
- Weight 5.4 kg

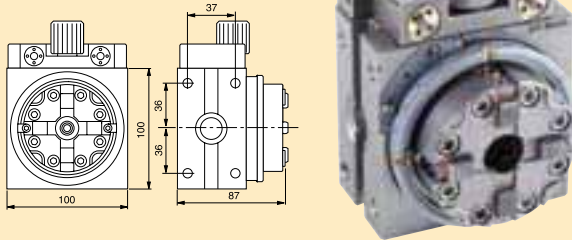

**Adapter  
3R-SP6435**

Adapter element for mounting 3R-217-1 in the WEDM system.

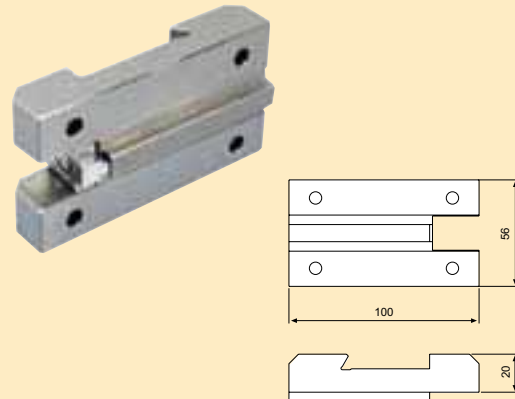

**Manual chuck MacroJunior  
3R-422.2**

Chuck adapter with axial locking screw for MacroJunior holders in the WEDM system.

- Fixed index positions 3x120°
- Weight 1.8 kg

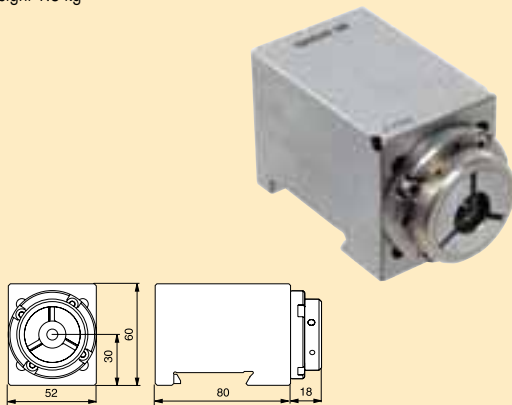

**Manual chuck MacroJunior  
3R-402.1**

Chuck for MacroJunior holder. Can be mounted on 3R-237.2, 3R-292.66HP, 3R-294, the 3Ruler system, or on Macro element 54x54.

- Required drawbar 3R-405.21RS
- Rust-resistant
- Fixed index positions 3x120°
- Weight 1.2 kg

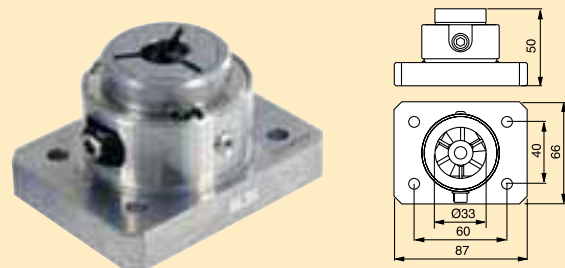

**Manual chuck MacroJunior  
3R-466.40RS**

Chuck adapter, stainless steel, for MacroJunior holders in the Macro system. Axial locking screw.

- Fixed index positions 3x120° and 4x90°
- Weight 0.4 kg

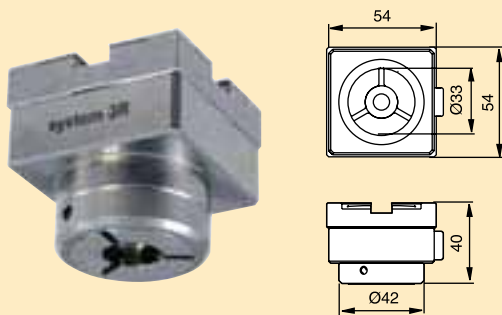

**Manual chuck adapter  
3R-406.9**

For horizontal mounting of MacroJunior holder in the Macro system. Screw locking.

- Adapted for automatic changing
- Rust-resistant
- Fixed index positions 3x120°
- Weight 1.2 kg

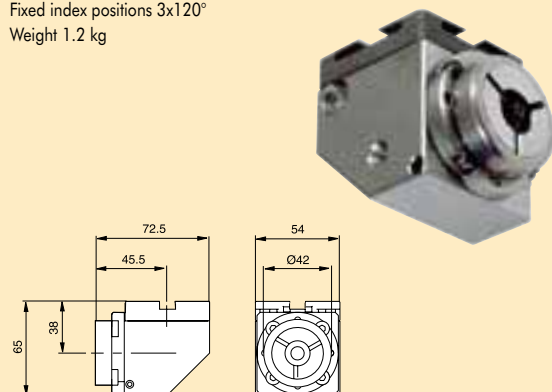

### Manual chuck for Mini 3R-252.1

Chuck adapter with dual hydraulic chambers for Mini holders in the WEDM-system.

- Fixed index positions 4x90°
- Weight 1.6 kg

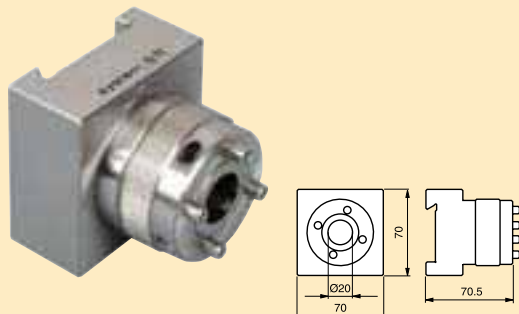

### MiniBlock 3R-202

Manual chuck with dual hydraulic chambers for Mini holders. Vertical or horizontal mounting in the WEDM system.

- Fixed index positions 4x90°
- Weight 1.9 kg

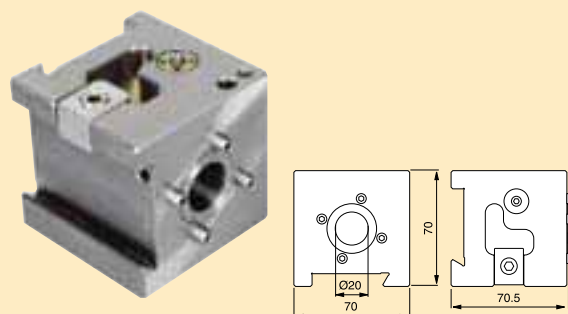

### Manual chuck for Mini 3R-222.2

Chuck adapter with dual hydraulic chambers for Mini holders in the WEDM-system.

- Fixed index positions 2x90°
- Weight 2.5 kg

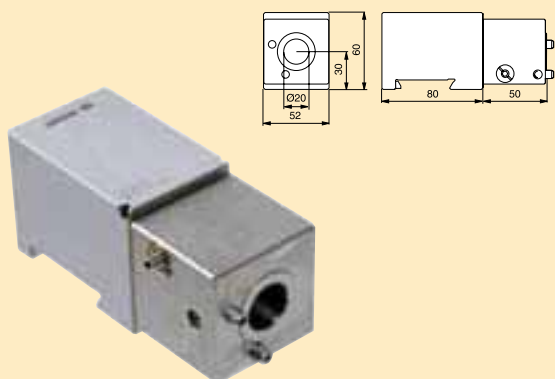

### Locking ring key 3R-605-GE

To lift the drawbar locking ring.

- Supplied in sets of two.



### Drawbars

#### 3R-405.21RS

- Drawbar Ø15x24 mm
- Rust-resistant
- Supplied singly



#### 3R-605.5RS

- Drawbar Ø20x19 mm
- Rust-resistant
- Supplied singly



#### ✓ 3R-605.2RS

- Drawbar Ø20x36.9 mm with flushing hole Ø7 mm
- Rust-resistant
- Supplied singly



#### ✓ 3R-605.27RS

- Drawbar Ø20x27 mm
- Rust-resistant
- Supplied singly



**THE HOLDERS HAVE BEEN ADAPTED**

for modern machines with high flushing pressure. These holders are mainly intended for clamping small to medium-sized workpieces on the zero line of the machine.

An example is the manufacture of electrodes for die-sinking EDM. The electrode is manufactured on its holder in the wire EDM machine. The electrode on its holder is then ready for immediate use in the die-sinking EDM machine, without intervening mounting operations and adjustments.

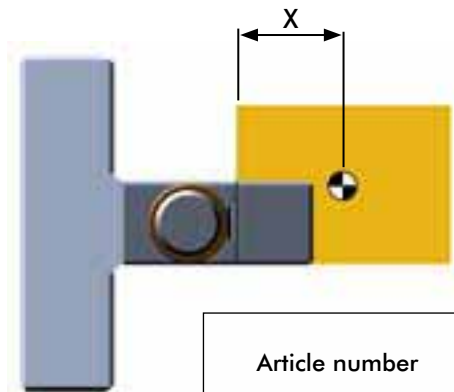
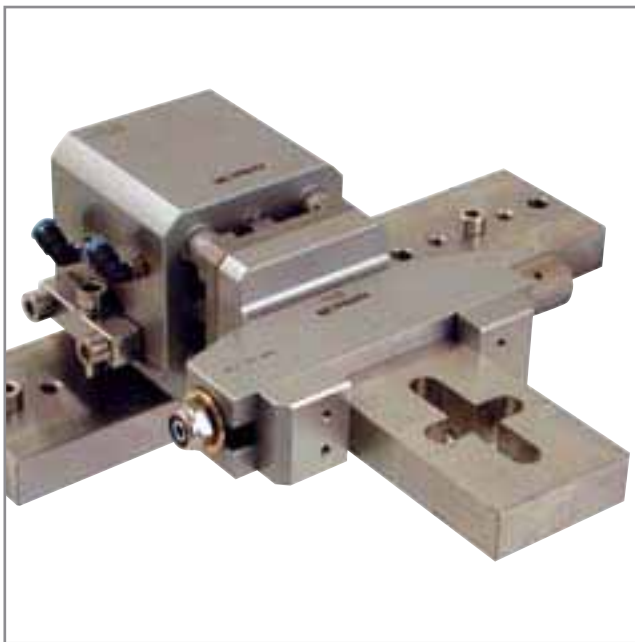

| Article number | Recommended maximum torque | Maximum workpiece weight X* = 50 mm | Maximum workpiece weight X* = 1000 mm |
|----------------|----------------------------|-------------------------------------|---------------------------------------|
| 3R-613.4       | 3.0 Nm                     | 6 kg                                | 3.0 kg                                |
| 3R-232.8       | 12.5 Nm                    | 25 kg                               | 12.5 kg                               |
| 3R-613.6       | 12.5 Nm                    | 25 kg                               | 12.5 kg                               |
| 3R-213.4       | 3.0 Nm                     | 6 kg                                | 3.0 kg                                |

\*Centre of gravity of the workpiece with X mm overhang

**✓ Pallet Macro 54x54 mm  
3R-651.7E-P**

Hardened and precision-cast, with clearance holes for four fixing screws.

*Note: Must be mounted on the workpiece/fixture before it is locked in a chuck.*

- Adapted for automatic changing
- Parallel-ground top and bottom faces
- Fixed index positions 4x90°
- Rust-resistant
- Supplied in sets of eight
- Weight per set 1.2 kg

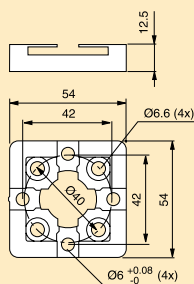
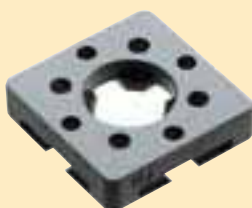

**✓ Pallet Macro 70x70 mm  
3R-601.7E-P**

Hardened and precision-cast, with clearance holes for eight fixing screws.

*Note: Must be mounted on the workpiece/fixture before it is locked in a chuck.*

- Adapted for automatic changing
- Parallel-ground top and bottom faces
- Fixed index positions 4x90°
- Rust-resistant
- Supplied in sets of five
- Weight per set 3 kg

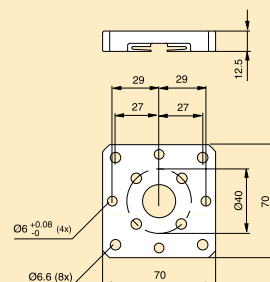
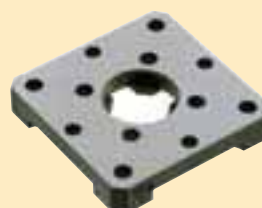

✓ Pallet WEDM  
3R-205.2

Unhardened holder for mounting in the WEDM system.

- Recommended maximum workpiece weight 7 kg
- Rust-resistant
- Weight 1 kg

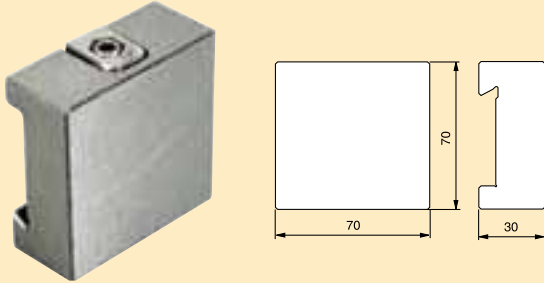

SuperVice Macro  
3R-613.4

Vice for mounting rectangular workpieces 0-25 mm in the Macro system.

- Rust-resistant
- Tightening torque 3 Nm
- Weight 0.6 kg

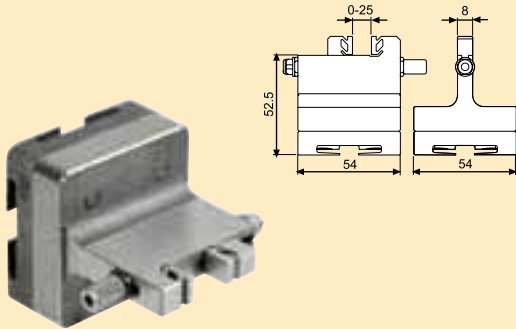

SuperVice WEDM  
3R-232.8

Vice for mounting rectangular (<60 mm) and round (8-45 mm) workpieces in the WEDM system.

- Rust-resistant
- Tightening torque 15 Nm
- Weight 1.5 kg

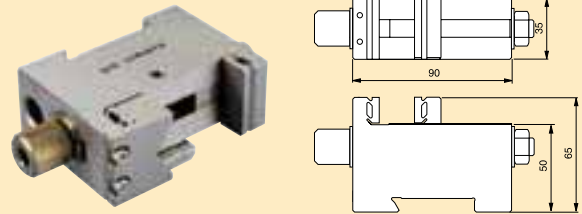

Macro vice  
3R-613.6

Vice for mounting rectangular workpieces 0-80 mm in the Macro system. Movable jaws for centred mounting. Can be supplemented with insert 16115 for mounting round workpieces 15-55 mm.

- Rust-resistant
- Tightening torque 15 Nm
- Weight 2.4 kg

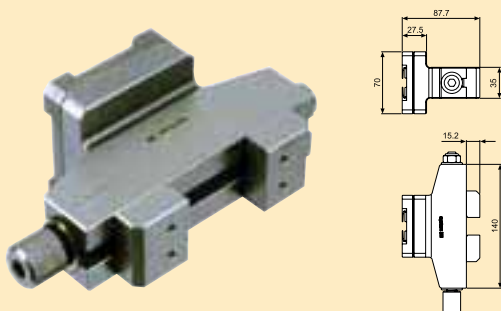

Macro V-holder  
3R-207.6

For clamping round workpieces 8-70 mm, or rectangular workpieces 10-52 mm in the Macro system.

- Hardened
- Rust-resistant
- Recommended maximum workpiece weight 8 kg
- Weight 2 kg

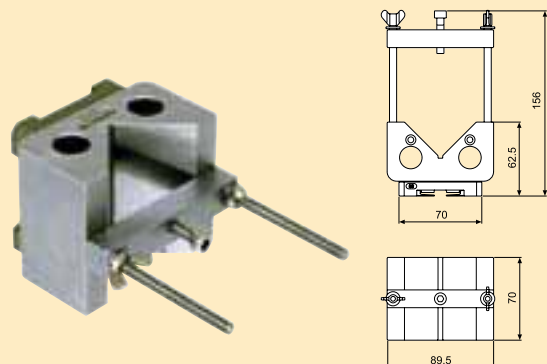

**Macro V-holder  
3R-208.6**

For clamping round workpieces 25-160 mm in the Macro system.

- Hardened
- Rust-resistant
- Recommended maximum workpiece weight 12 kg
- Weight 5.5 kg



**SuperVice Mini  
3R-213.4**

Vice for mounting rectangular workpieces up to 25 mm in the Mini system.

- Rust-resistant
- Tightening torque 3 Nm
- Weight 0.4 kg

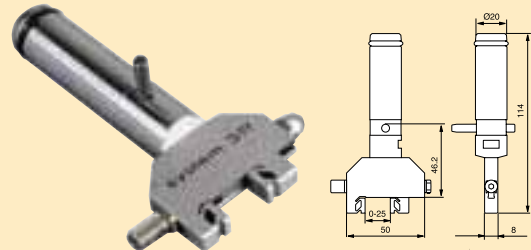

**3Ready-to-Run  
3R-494-XXX**

Blanks mounted on MacroJunior holders for the manufacture of electrodes. The stock range is matched to local preferences and ways of working. This applies to electrode materials, different grades of graphite and copper, and to dimensions. Contact your local 3R representative for further information.

The Vällingby factory can supply holders with factory-mounted copper blanks in sets of ten, as shown in the table.

| Article number  | Dimensions               |
|-----------------|--------------------------|
| 3R-494-D10x50   | Round blank Ø10x50 mm    |
| 3R-494-D12x50   | Round blank Ø12x50 mm    |
| 3R-494-D16x50   | Round blank Ø16x50 mm    |
| 3R-494-D22x50   | Round blank Ø22x50 mm    |
| 3R-494-D26x50   | Round blank Ø26x50 mm    |
| 3R-494-D32x50   | Round blank Ø32x50 mm    |
| 3R-494-D40x50   | Round blank Ø40x50 mm    |
| 3R-494-D50x50   | Round blank Ø50x50 mm    |
| 3R-494-S12x50   | Square blank 12x12x50 mm |
| 3R-494-S22x50   | Square blank 22x22x50 mm |
| 3R-494-S26x50   | Square blank 26x26x50 mm |
| 3R-494-S32x50   | Square blank 32x32x50 mm |
| 3R-494-S40x50   | Square blank 40x40x50 mm |
| 3R-494-32x22x50 | Square blank 32x22x50 mm |
| 3R-494-40x22x50 | Square blank 40x22x50 mm |

**✓ Holder Mini  
3R-322/50E**

Electrode holder for the Mini system with 50 mm long unhardened electrode mounting part.

- Adapted for automatic changing
- Hardened reference part
- Flushing duct
- Supplied in sets of thirty
- Weight per set 7.7 kg



### ADAPTER ELEMENTS ALLOW

machining of complex geometries, even if the machine is not the very latest model. The range includes products for swivelling or height adjustment, as well as plain spacer elements.

All adapter elements are hardened and rust-resistant.

#### Adapter WEDM 90° 3R-201J

- Weight 2.7 kg

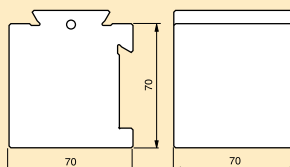

#### Swivelling element WEDM 360° 3R-203

Hydraulic locking of set position.

*Note: For angle setting, 3R-216 is recommended.*

- Weight 1.5 kg

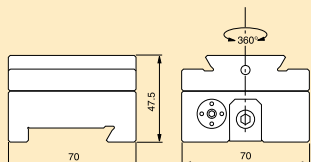

#### Swivelling element Macro 360° 3R-203.6

Hydraulic locking of set position. Supplied with drawbar 3R-605.27RS.

*Note: For angle setting, 3R-606.1 and sine ruler 3R-216 are recommended.*

- Weight 2.7 kg

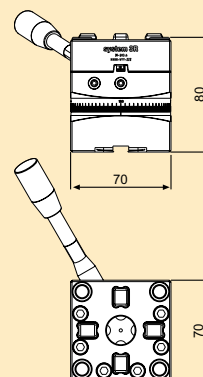

#### Height adapter WEDM 3R-204

- Height adjustment  $\pm 70$  mm
- Weight 1.9 kg

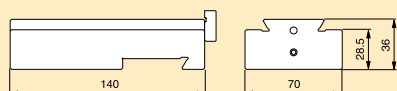

#### Angled holder, Macro 3R-226.6

For horizontal clamping SuperVice and holders in vertical Macro chucks.

- Weight 1.4 kg.

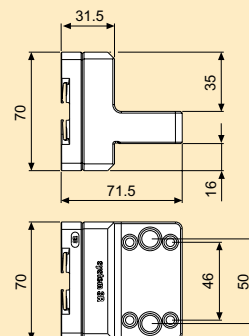

Spacer element WEDM 30 mm

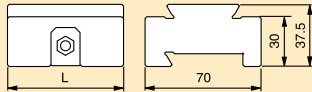

**3R-223**

- Length 70 mm

**3R-223.3**

- Length 140 mm

Spacer element WEDM 90°  
**3R-224**

- 70x70x30 mm
- Weight 1.1 kg

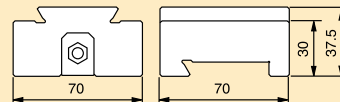

Adapter Macro  
**3R-602**

For mounting WEDM accessories on machine tables fitted with Macrochuck.

- Drawbar required
- Weight 1.2 kg

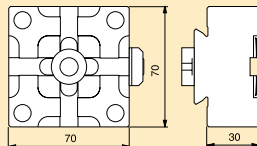

Vertical levelling adapter Macro  
**3R-262.6**

For horizontal mounting of SuperVice and holders in vertical Macro chucks.

- Adjustable in three axes
- Weight 1.5 kg

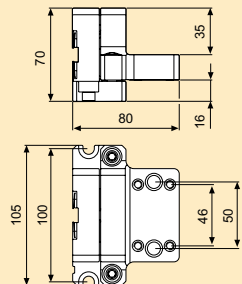

User kit  
**3R-243.2-1**

|             |                        |    |
|-------------|------------------------|----|
| 3R-201J     | Adapter 90             | x1 |
| 3R-204      | Height adapter         | x1 |
| 3R-602.27-1 | Manual chuck for Macro | x1 |
| 3R-605.27RS | Drawbar                | x1 |
| 3R-333-03   | Allen key, 3 mm        | x1 |
| 3R-333-05   | Allen key, 5 mm        | x1 |



## THE 3RULER RULER SYSTEM

has been developed for clamping medium-sized and large workpieces in machines with a parallel or U-shaped machine table, as well as for machines with a frame table. The rulers, which have built-in height adjustment, are used singly or in pairs.

With the aid of 3Ruler, rectangular or round workpieces, lightweight or heavy, large or small, are located on the machine zero line, without risk of collision. A comprehensive range of accessories gives an unsurpassed range of applications.

- ▶ *Machine-adapted ruler lengths*
- ▶ *Repeatable accuracy with the aid of reference elements*
- ▶ *Stable mounting of large workpieces*
- ▶ *A broad range of accessories gives great flexibility*

### 3Ruler

#### 3R-239-XXX

The rulers are available in various lengths (-XXX), to match different machines. The cross-section is matched to the length to ensure optimal stability.

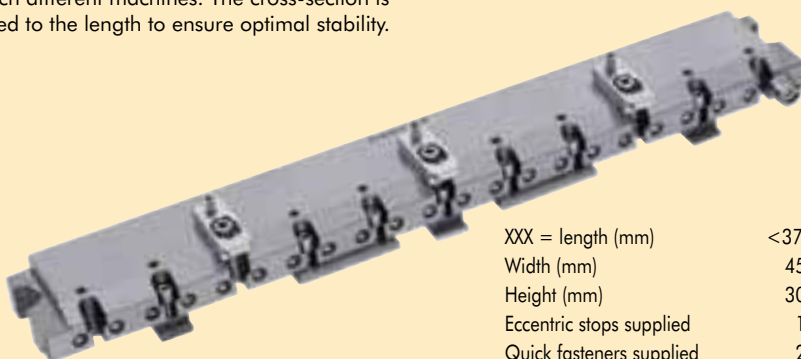

| XXX = length (mm)        | <370 | 371-595 | 596-950 | >950 |
|--------------------------|------|---------|---------|------|
| Width (mm)               | 45   | 60      | 86      | 86   |
| Height (mm)              | 30   | 30      | 36      | 36   |
| Eccentric stops supplied | 1    | 1       | 1       | 1    |
| Quick fasteners supplied | 2    | 2       | 2       | 2    |
| Zero line tabs supplied  | 2    | 2       | 3       | 5    |
| 5 mm tabs supplied       | 2    | 2       | 2       | 3    |
| Clamps supplied          | 2    | 2       | 3       | 5    |

### ✓ 3Ruler 3R-209B

Universal ruler for mounting directly on the machine table. Fits machine tables with hole pitch 400-565 mm. Length 595 mm.

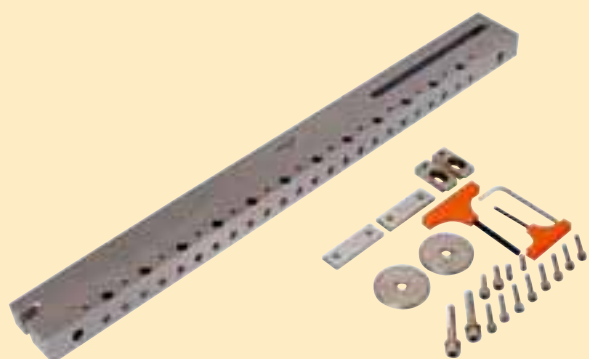



**Double-sided 3Ruler  
3R-239-XXX-D**

Double-sided rulers are available in various lengths (-XXX), to match different machines. The cross-section is matched to the length to ensure optimal stability. With these rulers, accessories can be clamped on both sides of the ruler.

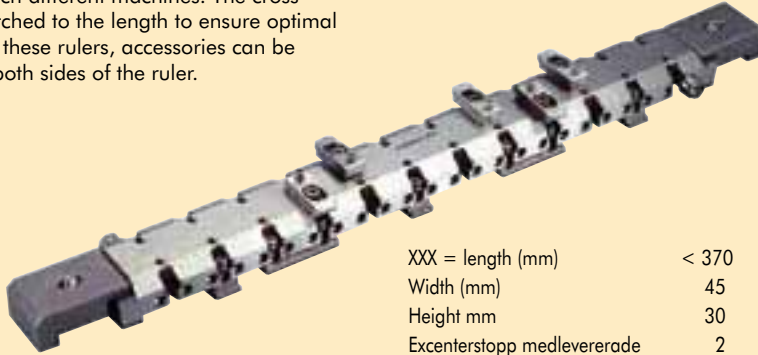

| XXX = length (mm)           | < 370 | 371-595 | 596-950 | > 950 |
|-----------------------------|-------|---------|---------|-------|
| Width (mm)                  | 45    | 60      | 86      | 86    |
| Height mm                   | 30    | 30      | 36      | 36    |
| Excenterstopp medlevererade | 2     | 2       | 2       | 2     |
| Quick fasteners supplied    | 2     | 2       | 2       | 2     |
| Zero line tabs supplied     | 4     | 4       | 6       | 10    |
| 5 mm tabs supplied          | 4     | 4       | 4       | 6     |
| Clamps supplied             | 4     | 4       | 6       | 10    |

**✓ Ruler vice  
3R-239.1**

Movable jaws of SuperVice design provide a wide clamping range for rectangular workpieces. Detachable Z-support tabs ensure simple setting-up.

- Hardened
- Recommended maximum workpiece weight with one vice: 15 kg
- Recommended maximum workpiece weight with two vices: 200 kg
- Tightening torque 8 Nm
- Weight 0.7 kg

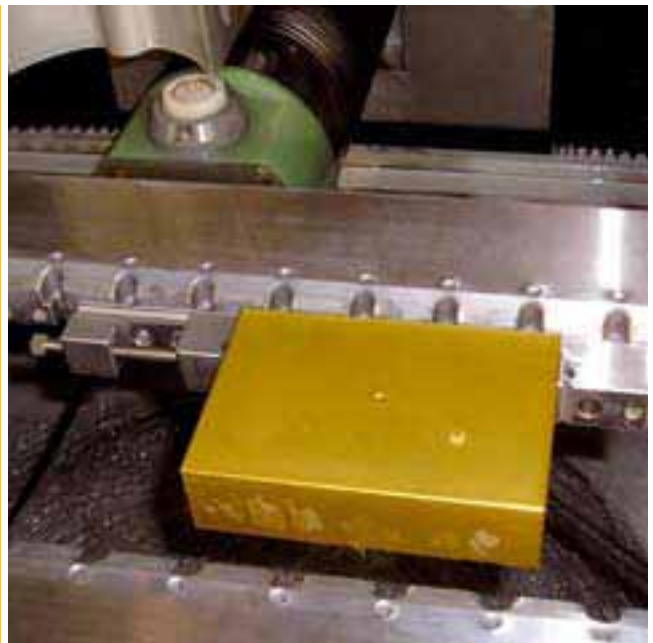

**✓ Low-profile holder  
3R-239.2**

For clamping thin workpieces.

- Hardened
- Clamping range 0-27 mm
- Supplied in sets of four
- Weight per set 0.6 kg



**✓ Vee holder  
3R-239.3**

For clamping round workpieces. To be mounted on ruler 3R-237.2 or 3R-292.66HP.

- Hardened
- Clamping range Ø25-300 mm
- Weight 0.9 kg



### ✓ 3Ruler kit 3R-239.20

Kit for clamping rectangular, round or thin workpieces.

Contents:

|            |                     |    |
|------------|---------------------|----|
| 3R-239.1   | Ruler vice          | x1 |
| 3R-239.2   | Low-profile holder  | x1 |
| 3R-239.3   | Vee holder          | x1 |
| 3R-914-10L | Torque wrench, 8 Nm | x1 |
| 3R-333-03  | Allen key, 3 mm     | x1 |
| 45600-N039 | Allen key, 4 mm     | x1 |



### Double ruler vice 3R-239.11

Movable jaws for mounting two rectangular workpieces at the same time. Detachable Z-support tabs ensure simple setting-up.

- Hardened
- Recommended maximum workpiece weight 7 kg
- Tightening torque 8 Nm
- Weight 1 kg

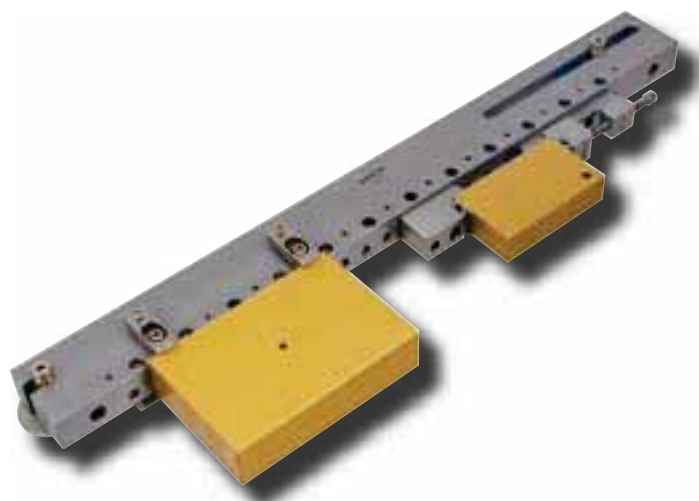

### Reference stop 3R-225.2

For positioning 3Ruler anywhere on the reference elements. The stops have adjusting screws for accurate alignment.

- Supplied in sets of two
- Weight per set 0.6 kg



### Vice 3R-294.2

Mounts on 3R-237.2, 3R-292.12, 3R-292.66HP, 3R-294, a ruler in the 3Ruler system or Macropallet 54x54.

- Hardened
- Clamping range 0-50 mm
- Recommended maximum workpiece weight 5 kg
- Tightening torque 3 Nm
- Weight 1.2 kg



**Vice  
3R-294.1**

For clamping workpieces up to 17 mm. Mounts on 3R-237.2, 3R-292.12, 3R-292.66HP, 3R-294 or a ruler in the 3Ruler system.

- Recommended maximum workpiece weight 2.5 kg
- Tightening torque 3 Nm
- Weight 0.5 kg



**Multiple holder  
3R-294.6**

For mounting of four workpieces  $\varnothing 5-13$  mm at the same time. Mounts on 3R-237.2, 3R-292.12, 3R-292.66HP, 3R-294 or a ruler in the 3Ruler system.

- Tightening torque 3 Nm
- Weight 0.6 kg



**Clamps  
3R-A239.1**

Clamps for clamping rulers on reference elements. Supplied in sets of two.



**Zero-line support tab 5 mm  
3R-239.22**

- Hardened
- Recommended maximum workpiece weight per stop 50 kg
- Supplied in sets of two.



**Miniclamps  
3R-239.24**

For clamping thin workpieces. To be fitted together with zero-line support tab.

- Recommended maximum workpiece weight per stop 1 kg
- Supplied in sets of two.



**Clamps  
3R-A239**

Clamps of aluminium for mounting a ruler directly on the machine table without reference elements.

- Supplied in sets of two, with M8 screw and washers
- Weight per set 0.3 kg

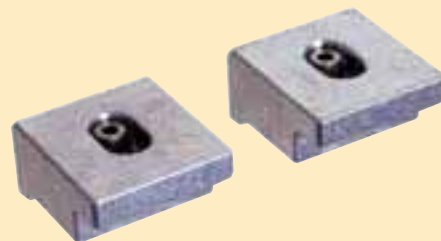

## MINIMAL RISK OF COLLISION

with three-point clamping. 3P is equally well suited to rectangular or round workpieces. Clamping takes only a few seconds.

3P has been developed for medium-sized and large workpieces in wire-EDM machines with an L-shaped or U-shaped machine table, as well as in machines with a frame table. The holders are matched to the size of the workpiece by sliding them along the reference element. The holders can be adjusted vertically.

- ▶ *Can be aligned in the machine*
- ▶ *Gives great flexibility*
- ▶ *Excellent value for money*
- ▶ *Easy cleaning*
- ▶ *Mounting on or above the zero line of the machine*

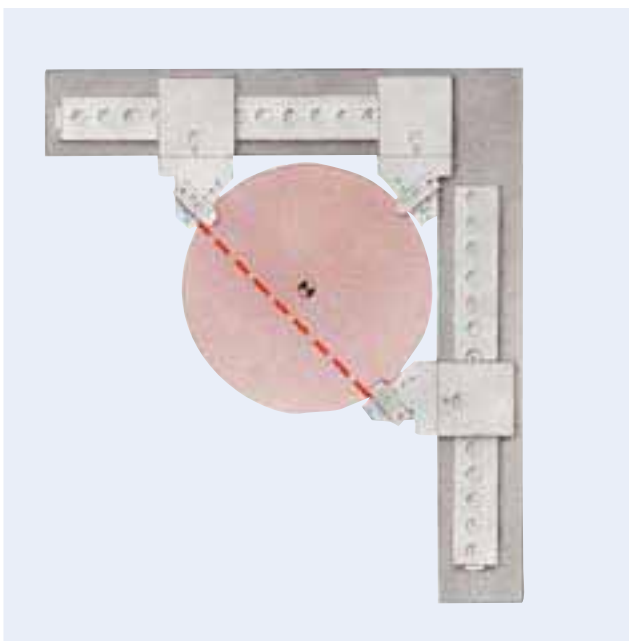
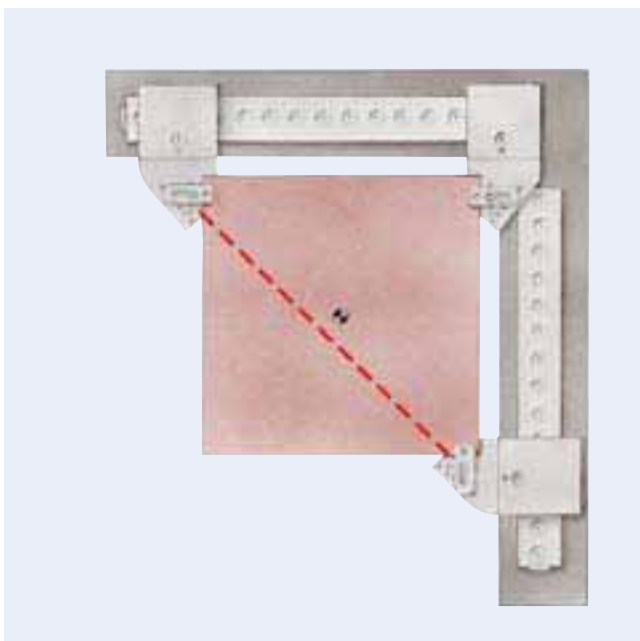
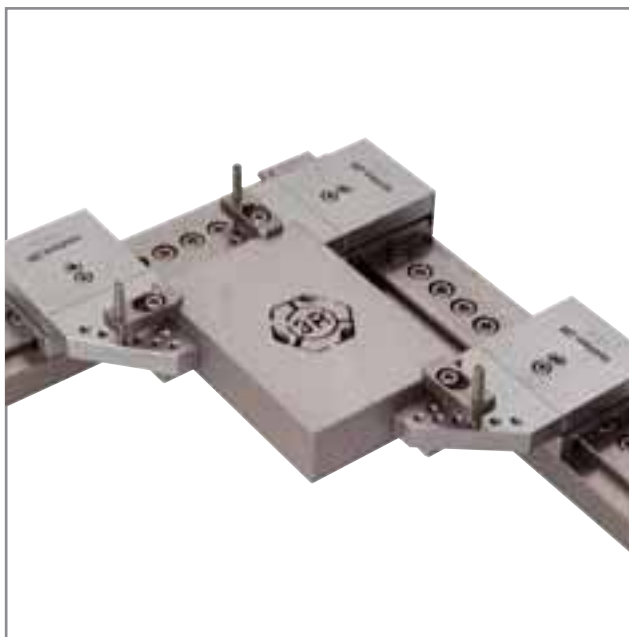

### Holder set 3R-218S

Set of three holders and fixing parts.

- Reversible jaws
- Holder length 70/23.5 mm.
- Recommended maximum workpiece weight 60 kg
- Weight per set 3 kg



**MAKE EFFICIENT USE OF MACHINE TIME**

Machine time can be used either for active machining or for non-productive setting-up operations on an idle machine.

You can optimise machine capacity by presetting away from the machine in a presetting station, while the machine is actively working on another workpiece.

So – preset away from the machine, lift in the preset package, secure it with a few simple manual operations, press the start button and the wire EDM machine is working again – One Minute Set-up.

System 3R’s presetting stations are constructed on a modular system, where the customer chooses a suitable packet of prepared “measuring stones”, for which the customer chooses the necessary chuck/reference elements in order to match the installation on the wire EDM machine table, as well as a pneumatic control unit if required.

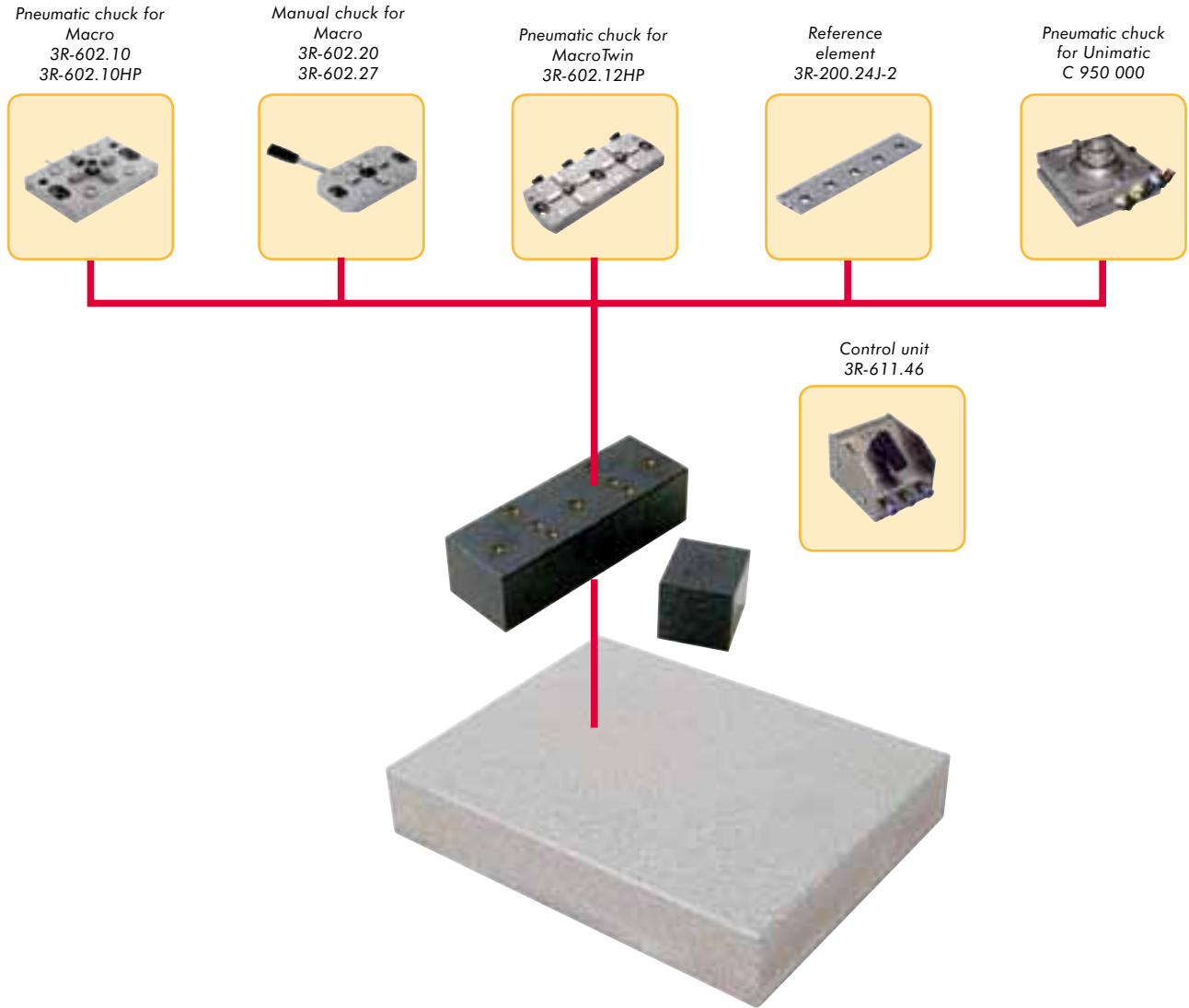

**Presetting stone  
3R-228J**

Stone with three ground faces, a reference element and a clearance stone. Together with a surface plate and a dial indicator, 3R-228J is an excellent presetting tool for a modest outlay.

- Dimensions 150x110x80 mm
- Weight 5.4 kg



**Presetting station  
3R-228S**

Mounting stone with bushings and holes for mounting chuck/reference elements, as well as a check stone. Use together with existing measuring machine or surface plate and a dial indicator.

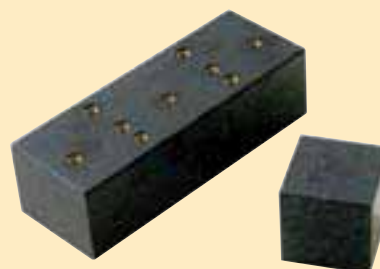

**Presetting station  
3R-228.1**

Surface plate with reference stops, a mounting stone with bushings and holes for mounting a chuck/reference element and through holes for mounting on the surface plate, and a check stone. A dial indicator is required.

- Dimensions 500x300 mm

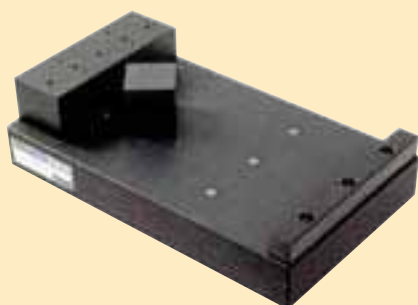

**Presetting station  
X 227 820**

Surface plate with reference stops, a mounting stone with bushings and holes for mounting a chuck/reference element and through holes for mounting on the surface plate, and a check stone. A dial indicator is required.

- Dimensions 800x500 mm

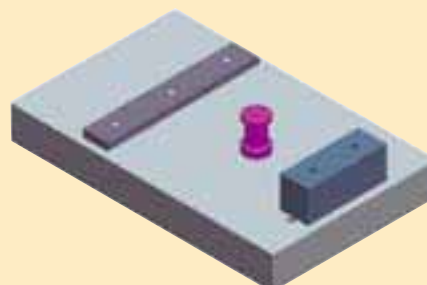

**Sine ruler  
3R-216**

With magnetic attachments for setting angles on swivelling elements. Angles are set with gauge blocks.

- Measuring length 50 mm
- Weight 1.2 kg

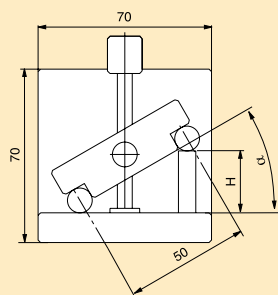

$$\sin \alpha = \frac{H}{50}$$

**Sine ruler Macro  
3R-216.6**

For setting angles on swivelling elements. Angles are set with gauge blocks.

- Measuring length 50 mm
- Weight 1.4 kg

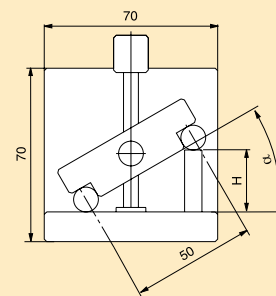

$$\sin \alpha = \frac{H}{50}$$

**Master  
3R-206.10**

Master for horizontal Macro chucks. One long side ground to the Macro references. Supplied with engraved dimensions in the X-, Y- and Z-directions.

- Supplied with drawbar 3R-605.10
- For automatic changing, 3R-WP1 must be added.



**Master  
3R-606.2**

Master for determining the position of vertical Macro chucks. Cylinder ground to the Macro references. Supplied with engraved dimensions in the X-, Y- and Z-directions.

- Supplied without drawbar

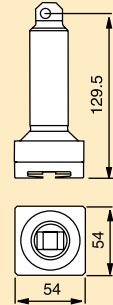

**Reference ball  
3R-215**

For finding positions of applications with swivelling elements.

- Magnetic attachment for Ø16 mm ball
- Supplied with two balls

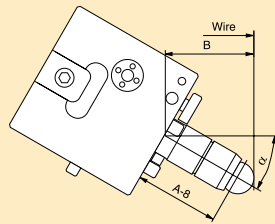

$$B = (A-8) \cos \alpha + 8$$

**Actuator  
3R-611.46**

Unit for operation of pneumatic chucks. Three functions – open/neutral/closed.



**Wire alignment unit  
3R-220.3**

Unit with double-insulated reference contacts for wire alignment.

- For Mitsubishi machines
- Four wires in the cable
- Weight 2.2 kg

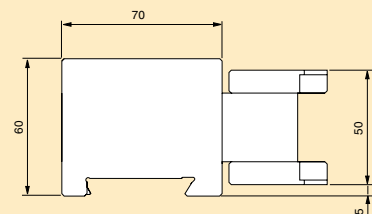

## REALLY SMALL PARTS

that are difficult to produce in lathes or grinders can usefully be wire-EDMed using a rotating spindle on the machine table.

### Rotating spindle 3R-6.600-VHS

For clamping in a horizontal Macro chuck. Flushing via the spindle or an external flushing connection.

- Control unit included
- Drawbar depends on chosen chuck
- Rust-resistant
- Immersible
- Speed range 60-1500 rev/min
- Maximum workpiece weight 5 kg
- Maximum flushing pressure through the chuck 15 bar
- Maximum external flushing pressure 40 bar
- Weight 9.5 kg



### Rotating spindle 3R-6.300-EHS16

For clamping in a vertical Macro chuck. Flushing via the spindle or an external flushing connection. Recommended collets – Balzer EHS16, Regofix ER16 or Tecnopinz ETS16.

- Control unit included
- Drawbar depends on chosen chuck
- Rust-resistant
- Immersible
- Speed range 60-2000 rev/min
- Maximum flushing pressure through the chuck 15 bar
- Maximum external flushing pressure 40 bar
- Weight 10 kg



### Support 3R-261.1

For mounting directly on the machine table.

- Adjustable length 35-135 mm
- Recommended maximum workpiece weight 20 kg
- Weight 1.5 kg

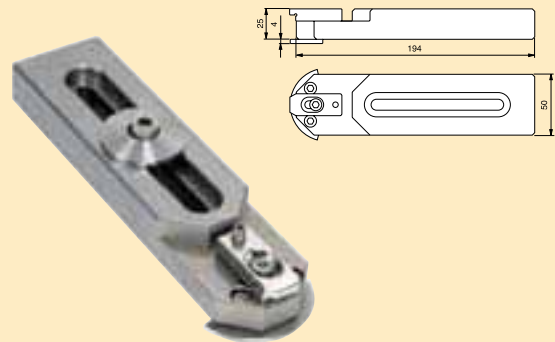

### Adjustable support WEDM 3R-261

- Adjustable length 38-138 mm
- Adjustable height 0-0.2 mm
- Recommended maximum workpiece weight 20 kg

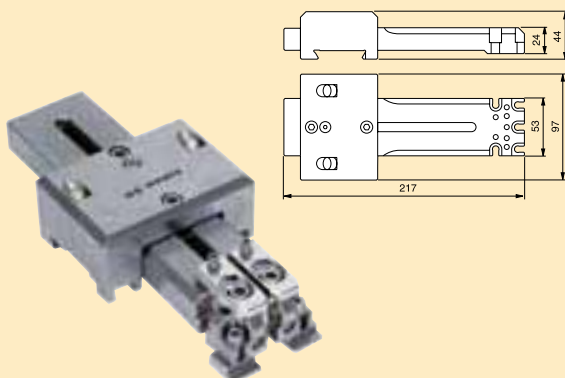

### Expanding mandrel 3Refix 3R-901-10RS

*Note: When positioning with 3Refix mandrels – always tighten the expanding mandrel in the R<sup>0</sup> hole first.*

- 3Refix Ø10 mm
- Rust-resistant
- Recommended tightening torque 4 Nm
- Supplied singly
- Weight 0.05 kg





**ICS ZEROLINE TOOLING**

is designed for fast, easy and universal use directly on the wire EDM machine table at the zeroline. ICS Zeroline can be mounted and set up very quickly and can be reconfigured or dismantled just as easily and quickly, regardless of whether it is designed as a clamping support, levelling head or clamping bar.

The ICS Zeroline range also features adapter elements allowing the user to use the entire range of ICS and Unimatic clamping elements for direct table mounting.

**ADAPTERS AND ADAPTATION ELEMENTS**

allow the user to utilise the entire diversity and all the strengths of the 3R clamping elements on his or her machine configuration.

Manual ICS and Unimatic adapters offer the option of mounting the clamping elements directly on Zeroline tables and nevertheless utilising the advantage of the levelling head.



**OVERVIEW ICS ZEROLINE SYSTEM**

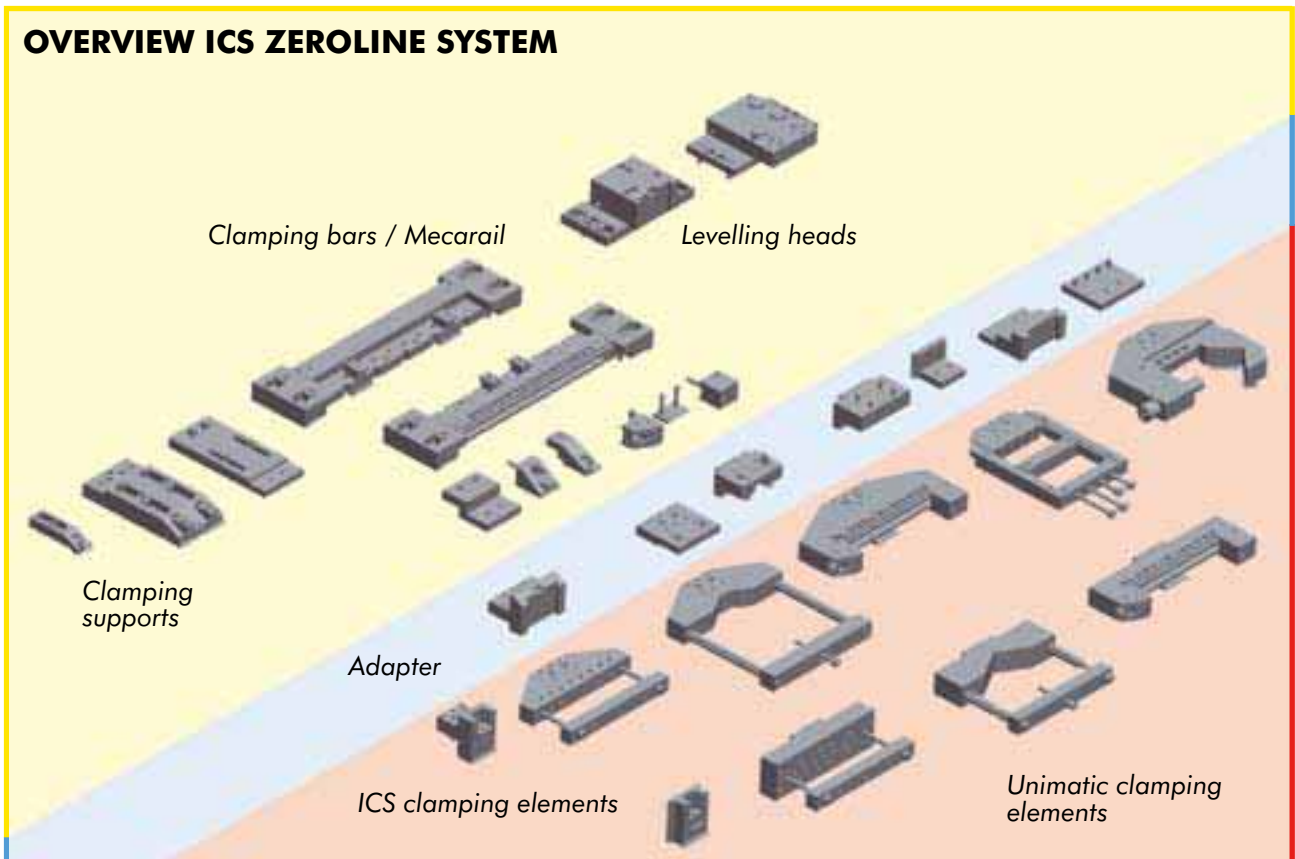

✓ **Set ICS Zeroline Mini**  
**S 150 500**

consisting of:

|           |                             |    |
|-----------|-----------------------------|----|
| C 666 020 | Clamping support 300        | x1 |
| C 666 040 | Clamping support 180        | x1 |
| N 150 000 | Support lips "4"            | x4 |
| C 666 022 | Support lips "0"            | x4 |
| S 150 350 | Set screws/prolongations M8 | x1 |
| N 153 010 | Bushings M8 (inkl. screws)  | x6 |
| N 153 020 | Bushings M6 (inkl. screws)  | x6 |
| E 100 007 | Set hexagon Allen wrench    | x1 |

Set packed in case



✓ **Set ICS Zeroline Go!**  
**S 150 550**

consisting of:

|           |                             |    |
|-----------|-----------------------------|----|
| C 666 020 | Clamping support 300        | x1 |
| C 666 040 | Clamping support 180        | x1 |
| C 642 050 | Flange 26/200               | x1 |
| N 150 000 | Support lips "4"            | x4 |
| C 666 022 | Support lips "0"            | x4 |
| S 150 350 | Set screws/prolongations M8 | x1 |
| N 153 010 | Bushings M8                 | x6 |
| E 100 007 | Set hexagon Allen wrench    | x1 |

Set packed in case



✓ **ICS Zeroline clamping support 300**  
**C 666 020**

Clamping support for the direct installation on WEDM machine table.

- Support lips „4“ and „0“
- Recommended maximum workpiece weight 50 kg in application as support element
- Weight 5.3 kg

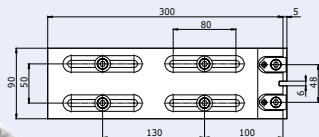
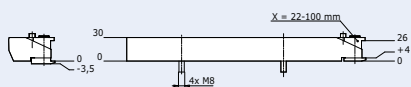

✓ **ICS Zeroline clamping support 180**  
**C 666 040**

Clamping support for the direct installation on WEDM machine table.

- Support lips „4“ and „0“
- ICS adaptation B&C for the installation of ICS clamps & holders
- Recommended maximum workpiece weight 50 kg in application as support element
- Weight 3.1 kg

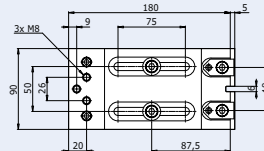
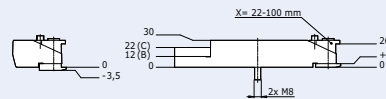

✓ **Set AC Vertex1**  
**S 150 560**

consisting of:

|           |                             |    |
|-----------|-----------------------------|----|
| C 666 060 | Clamping support 155        | x1 |
| C 557 300 | Vertex 1 clamping bar       | x1 |
| C 666 022 | Support lips "0"            | x4 |
|           | Set screws/prolongations M8 | x1 |
| E 100 007 | Set hexagon Allen wrench    | x1 |

Set packed in case

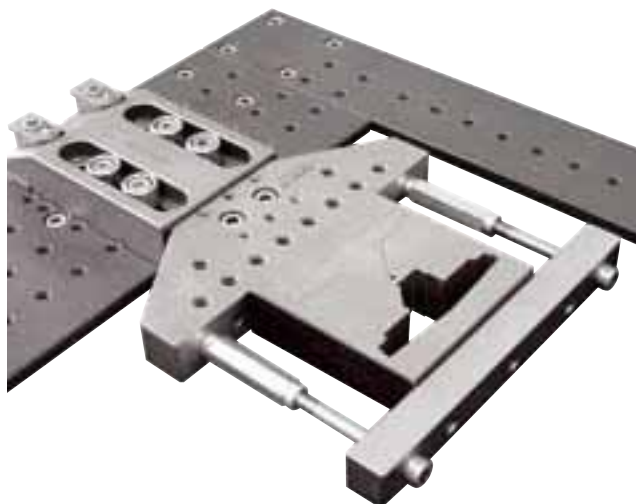

**✓ ICS Zeroline multi-adapter 250  
C 665 600**

Clamping support for the direct installation on WEDM machine table.

- Support lips „+4“ and „0“
- ICS adaptation B&C for the installation of ICS clamps & holders
- Recommended maximum workpiece weight 75 kg in application as support element
- Weight 5.3 kg

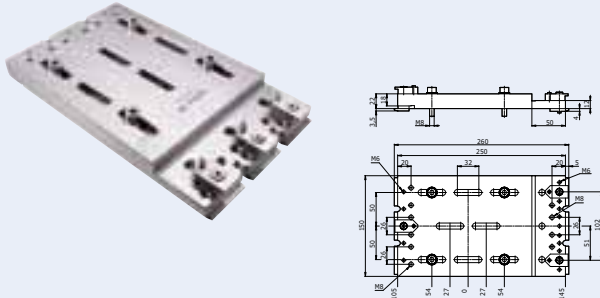

**✓ ICS Zeroline adapter B  
C 665 900**

Clamping support for the direct installation on WEDM machine table.

- Functional height: clamping of workpiece on  $Z = +4$  mm and  $Z = 0$  mm
- Recommended maximum workpiece weight 20 kg in application as support element
- Weight 0.5 kg

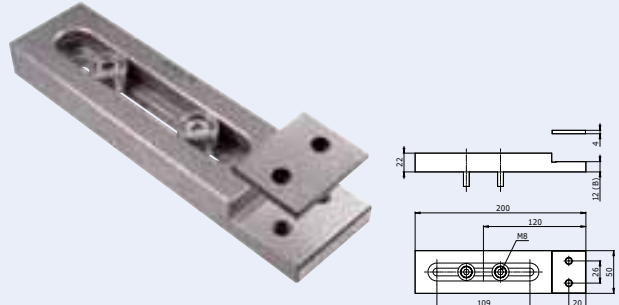

**✓ ICS Zeroline clamp 90  
C 552 630**

Clamping support for the direct installation on WEDM machine table.

- Functional height: clamping of workpiece on  $Z = 0$  mm
- Recommended maximum workpiece weight 20 kg in application as support element
- Weight 0.25 kg



**✓ ICS Zeroline clamp 150  
C 552 640**

Clamping support for the direct installation on WEDM machine table.

- Functional height: clamping of workpiece on  $Z = +4$  mm
- Recommended maximum workpiece weight 20 kg in application as support element
- Weight 0.5 kg

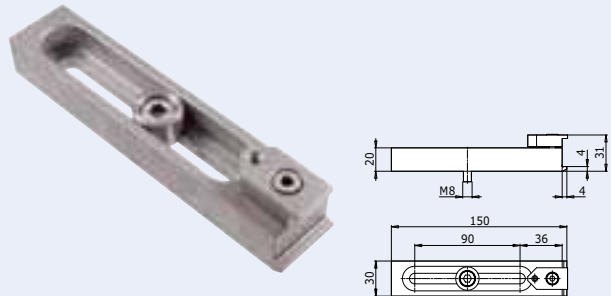

**✓ ICS Zeroline adapter A/B  
C 665 700**

Basic element for the adaptation of ICS clamping elements of the series A and B.

- Functional height: clamping of workpiece on  $Z = +4$  mm and  $Z = 0$  mm
- Adaptation height ICS A: 7 mm / ICS B: 12 mm
- Weight 1.5 kg

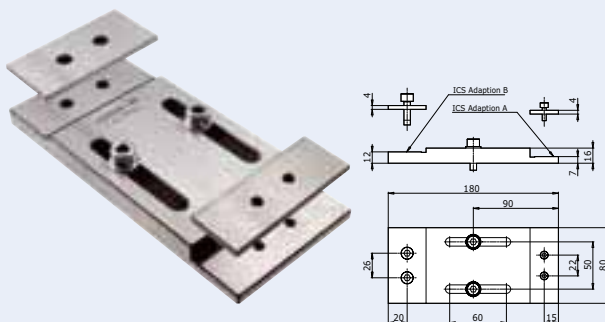

**ICS Zeroline adapter A/B short  
C 665 720**

Basic element for the adaptation of ICS clamping elements of the series A and B.

- Functional height: clamping of workpiece on  $Z = +4$  mm and  $Z = 0$  mm
- Adaptation height ICS A: 7 mm / ICS B: 12 mm
- Weight 1.1 kg

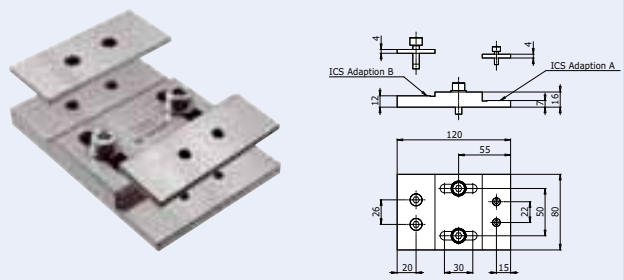

## ICS ZEROLINE MECARAIL AND ICS ZEROLINE CLAMPING BARS

are available in various sizes, matched to the wire EDM machine tables.

The brackets and screws required for attachment on the machine table are included in the scope of delivery.

Please use the selection table on our website ([www.system3r.com](http://www.system3r.com)) to determine the ICS Zeroline Mecarail or ICS Zeroline clamping bars specific to your machine or state the make of machine and type when ordering.

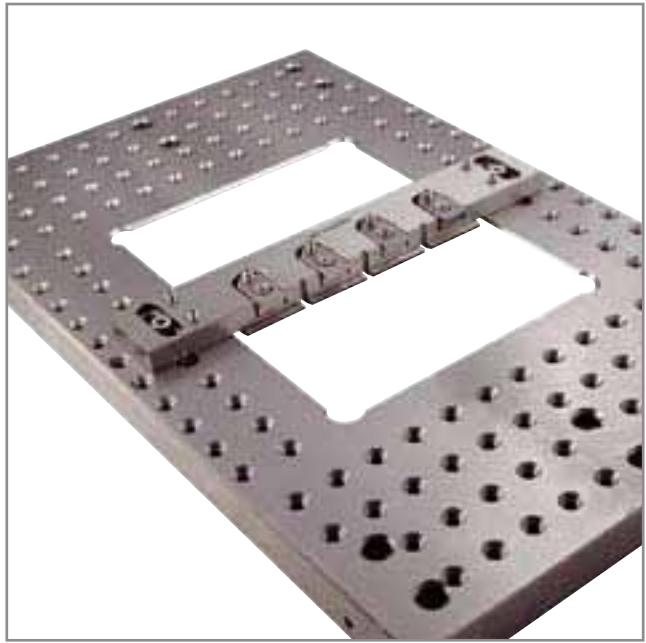

### ICS Zeroline Mecarail C 558 XXX

Double sided clamping bar, including brackets.

|                         |       |           |       |       |
|-------------------------|-------|-----------|-------|-------|
| Length                  | < 570 | 571 - 750 | > 750 |       |
| Width                   | 70    | 75        | 75    |       |
| Height                  | 30    | 35        | 40    |       |
| Length                  | < 380 | < 480     | <680  | < 750 |
| Number of lips/brackets | 2     | 3         | 4     | 6     |



### ICS Zeroline clamping bar C 557 XXX

Single sided clamping bar, including brackets.

|                         |       |           |       |       |
|-------------------------|-------|-----------|-------|-------|
| Length                  | < 570 | 571 - 750 | > 750 |       |
| Width                   | 70    | 70        | 70    |       |
| Height                  | 30    | 35        | 40    |       |
| Length                  | < 380 | < 480     | <680  | < 750 |
| Number of lips/brackets | 2     | 3         | 4     | 6     |



### Set ICS Zeroline Maxi S 206 4XX

\* When ordering, please state the machine type as well as X or Y axes.

consisting of:

|           |                          |    |
|-----------|--------------------------|----|
| C 558 0xx | Standard Mecarail *      | 1x |
| S 150 000 | Set Mecarail-Vice        | 1x |
| S 150 310 | Set base plates "+4"     | 1x |
| E 100 007 | Set hexagon Allen wrench | 1x |

Set packed in case (Mecarail in carton)

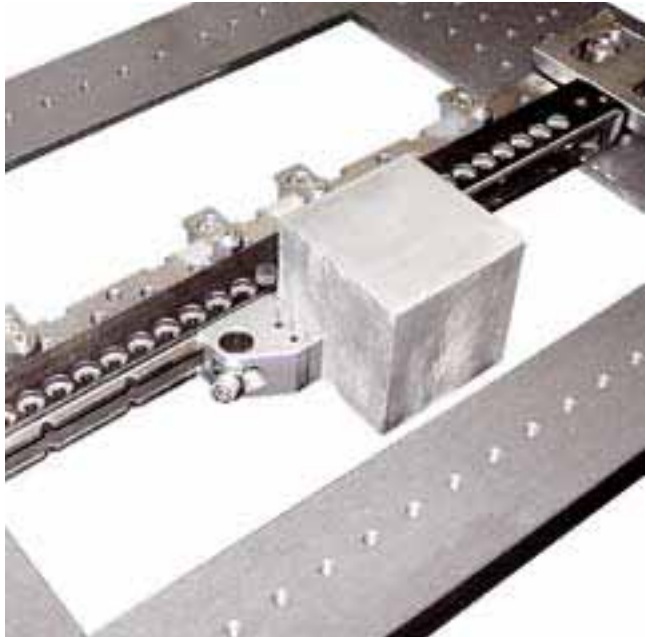

### ICS Adaptation A, B or C

Adapter to ICS Zeroline clamping bar C 557 xxx and ICS Zeroline Mecarail C 558 xxx for the adaptation of ICS clamping elements

- Weight approx. 0.7 kg

#### C 456 650

- Adaptation to all clamping elements ICS A
- Adaptation height 7 mm (ICS A)

#### C 456 660

- Adaptation to all clamping elements ICS B
- Adaptation height 12 mm (ICS B)

#### C 456 670

- Adaptation to all clamping elements ICS C
- Adaptation height 22 mm (ICS C)



### ICS Clamp C 552 620

The main application of the ICS clamp is fixing small workpieces of different dimensions.

- Functional height workpiece on „0 mm“, with intermediate plate „+4“
- Clamping range 0 – 10 mm
- Maximum workpiece weight 3 kg, not for overhung clamping!
- Adaptation to all ICS C 557 xxx
- Dimensions 80 x 28 mm
- Weight 0.2 kg



### Mecarail Clamp „+4“ C 552 600

The main application of the ICS clamp is fixing workpieces of different dimensions.

- Functional height workpiece on „+4 mm“
- Clamping range 0 – 20 mm
- Maximum workpiece weight 6 kg, not for overhung clamping!
- Adaptation to all Mecarail C 558 xxx
- Dimensions 40 x 55 x 30 mm
- Weight 0.2 kg



### Mecarail Clamp „0“ C 552 610

The main application of the ICS clamp is fixing workpieces of different dimensions.

- Functional height workpiece on „0 mm“
- Clamping range 0 – 20 mm
- Maximum workpiece weight 6 kg, not for overhung clamping!
- Adaptation to all Mecarail C 558 xxx
- Dimensions 40 x 55 x 34 mm
- Weight 0.2 kg



### ✓ Mecarail Vice S 150 000

Jaw set for Mecarail; with guide; for horizontal parallel clamping.

- Functional height 30 mm
- Maximum workpiece weight 15 kg
- Maximum workpiece dimensions 100 x 120 x 160 mm
- Adaptation to all Mecarail C 558 xxx
- Overall height 30 mm
- Weight 0.8 kg



### ✓ Mecarail Twinvice S 149 900

Twin-Jaw set for Mecarail; with guide; for horizontal parallel clamping.

- Functional height 30 mm
- Maximum workpiece weight 15 kg
- Maximum workpiece dimensions 100 x 120 x 160 mm
- Adaptation to all Mecarail C 558 xxx
- Overall height 30 mm
- Weight 1.2 kg

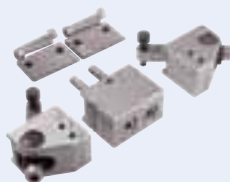

### Mecarail V-block C 597 560

Workpiece carrier for round parts; for the use on Mecarail.

- Functional height 30 mm
- Clamping range Ø20 – 150 mm
- Maximum workpiece weight 15 kg
- Maximum workpiece dimensions Ø150 x 100 mm
- Adaptation to all Mecarail C 558 xxx
- Dimensions 210 x 53 mm
- Weight 2.8 kg

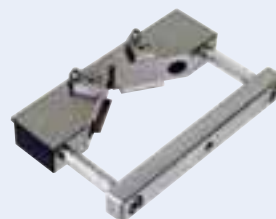

### ✓ Set base plates „+4“ S 150 310

4 mm baseplates for collision-free clamping of workpieces on Mecarails and clamping bars.

- Weight 0.2 kg

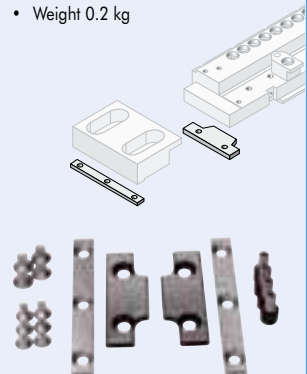

✓ **Unimatic Adapter manual with adjusting function**

**C 950 090**

Zeroline table adapter manual with adjusting function, for all Unimatic clamping elements.

- Functional height 45 mm
- Adjustment range  $\pm 0.2$  mm for all three axes
- Weight 3.8 kg

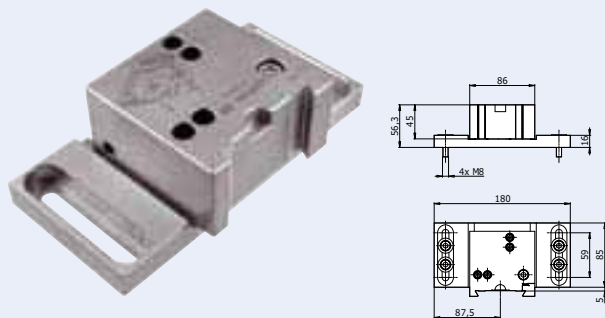

✓ **Unimatic Reference ruler**

**C 960 440**

Tool for setting workpieces to Zeroline on machine tables.

- Weight 1.5 kg

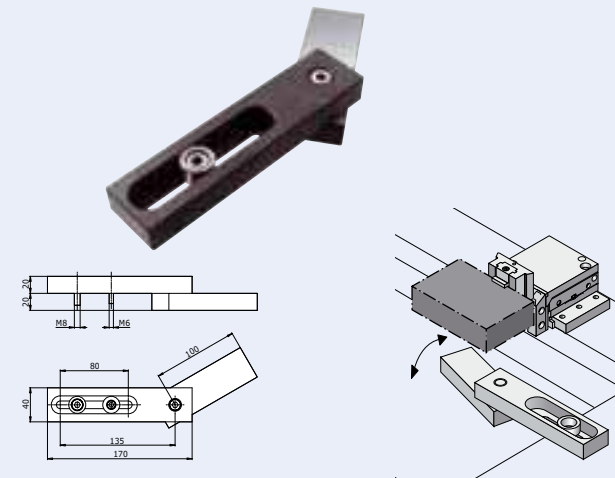

**ICS Levelling head**

**C 458 000**

Levelling head for direct mounting on Zeroline tables. Adaptation elements for Unimatic and all ICS clamping elements available.

- Adjustment range approx.  $\pm 1.0$  mm for all three axes
- Weight 3.4 kg

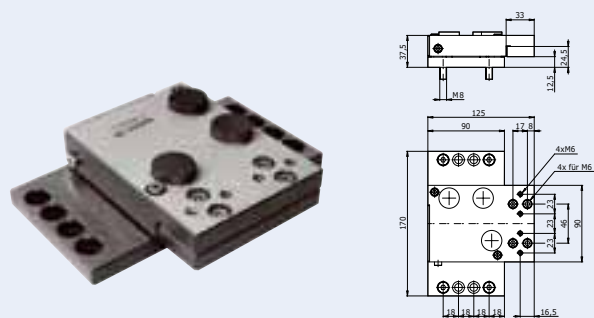

**ICS Adapter A, B or C**

Adapter to ICS levelling head C 458 000 and C 458 010 for the adaptation of ICS clamping elements.

- Dimensions 90 x 73 mm

**C 458 040**

- ICS A, Adaptation height 7 mm
- Weight 0.4 kg

**C 458 060**

- ICS B, Adaptation height 12 mm
- Weight 0.8 kg

**C 458 080**

- ICS C, Adaptation height 22 mm
- Weight 0.9 kg



**Unimatic Guide**

**C 950 290**

Adapter to ICS levelling head C 458 000 and C 458 010 for the adaptation of Unimatic clamping elements.

- Functional height 40 mm
- Dimensions 90 x 81 mm
- Weight 1.2 kg



## ICS GUIDE RAILS

Mounting hardened ICS guide bars on the Zeroline is a basic approach for a wide variety of clamping requirements and all ICS clamping elements like ICS clamps and holders, ICS guides and levelling units as well as ICS cross guides and slide elements.

Clamping and exact adjustment of the workpieces in the required position can be made directly in the WEDM machine or at the presetting station with control elements, which simulate a machine base.

The alignment of the clamping elements and thus also the workpieces are ensured by dovetail adapters. Since the guiding and the clamping surfaces are not identical, any clamping-related wear will not affect positioning accuracy.

Please use the selection table on our website ([www.system3r.com](http://www.system3r.com)) to determine the ICS guide rails specific to your machine or state the make of machine and type when ordering.

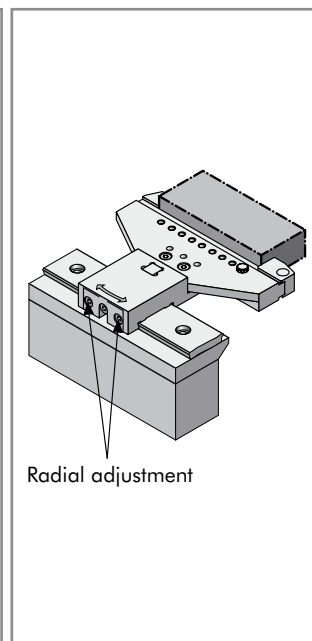
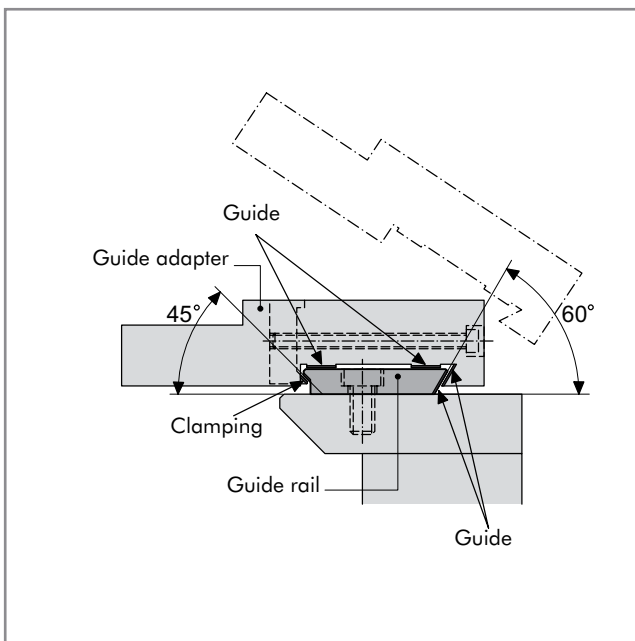

ICS Guide rails for installation in Agie zeroline tables.

- C 170 110 Classic 2
- Challenge 2
- Evolution 2
- Excellence 2
- C 170 130 Classic 3
- Challenge 3
- Evolution 3
- Excellence 3

Application:  
ICS Cross guide/slide and  
ICS Levelling head C 458 030

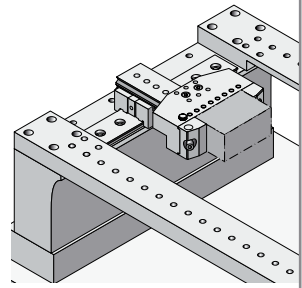

## OVERVIEW

Reference elements

ICS guide rails

ICS Holders and vices

Unimatic Holders and vices

### ICS Guide rail C 170 XXX

Guide element for the installation of ICS elements like ICS guide adapter and ICS levelling head.

- Dimensions 48.5 x 8 mm
- Weight depending on the length, approx. 0.26 kg/100 mm

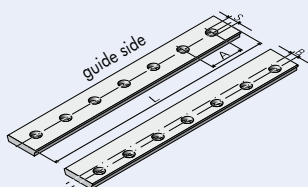

| Item no.  | L   | A    | B   | S     |
|-----------|-----|------|-----|-------|
| C 170 000 | 230 | 50   | -   | M8 x5 |
| C 170 050 | 230 | 50   | 5   | M8 x5 |
| C 170 110 | 280 | 40   | -   | M8 x7 |
| C 170 130 | 380 | 42,5 | -   | M8 x9 |
| C 170 150 | 220 | 25   | -   | M8 x9 |
| C 170 200 | 220 | 25   | 5   | M8 x9 |
| C 170 300 | 350 | 50   | -   | M8 x7 |
| C 170 600 | 350 | 50   | 5   | M8 x7 |
| C 170 650 | 120 | 25   | -   | M8 x4 |
| C 170 750 | 410 | 50   | 5   | M8 x7 |
| C 170 760 | 288 | 50   | 5   | M8 x6 |
| C 170 770 | 348 | 50   | 2   | M8 x7 |
| C 170 800 | 320 | 50   | 5   | M8 x6 |
| C 170 840 | 298 | 50   | 4   | M8 x6 |
| C 170 850 | 320 | 50   | 7.5 | M8 x6 |
| C 170 950 | 338 | 50   | 5   | M8 x7 |

### ✓ ICS Guide adapter A, B or C

Adapter with ICS adaptation for the use on ICS guide rails.

#### C 456 250

- ICS A (7/70)
- Functional height 7 mm
- Weight 1.1 kg

#### C 456 350

- ICS B (12/70)
- Functional height 12 mm
- Weight 1.3 kg

#### C 456 450

- ICS C (22/70)
- Functional height 22 mm
- Weight 1.5 kg



### ICS Levelling head C 458 010

Levelling head for the use on ICS guide rails. Adaptation elements for Unimatic and all ICS clamping elements available.

- Functional height 55.5 mm
- Adjustment range approx.  $\pm 1.0$  mm for all three axes
- Weight 3.4 kg

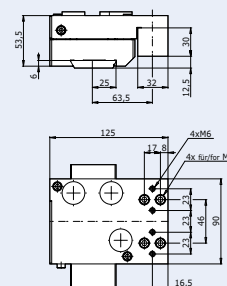

### ICS Adapter A, B or C

Adapter to ICS levelling head C 458 000 and C 458 010 for the adaptation of ICS clamping elements.

- Dimensions 90 x 73 mm

#### C 458 040

- ICS A, adaptation height 7 mm
- Weight 0.4 kg

#### C 458 060

- ICS B, adaptation height 12 mm
- Weight 0.8 kg

#### C 458 080

- ICS C, adaptation height 22 mm
- Weight 0.9 kg



### Unimatic guide C 950 290

Adapter to ICS levelling head C 458 000 and C 458 010 for the adaptation of Unimatic clamping elements.

- Functional height 40 mm
- Dimensions 90 x 81 mm
- Weight 1.2 kg





**ICS GUIDE ELEMENTS**

The time-proven ICS guide system, with the guide elements, offers various options for clamping workpieces in various positions.

The ICS guide elements are the connecting elements between the ICS beam and the ICS slides and the ICS slide clamping elements.

The ICS slides are the supports for the ICS clamping elements whose adapter faces are matched to series A, B and C.

The ground stop faces ensure a rectangular position of the bolted-on clamping elements.

**✓ ICS Cross guide  
C 300 050**

The connecting link between the ICS guide rail / ICS beam and the standard slide or the supporting clamping elements.

*Note: the outer faces of C 300 500 are ground at right angles to be used with limit stops.*

- Functional height 22 mm
- Weight 0.9 kg



**✓ ICS Cross guide universal  
C 300 100**

The connecting link between the ICS guide rail / ICS beam and the standard slide or the supporting clamping elements.

*Note: the outer faces of C 300 100 are ground at right angles. The two adjusting screws allow radial adjustment.*

- Functional height 22 mm
- Weight 0.9 kg

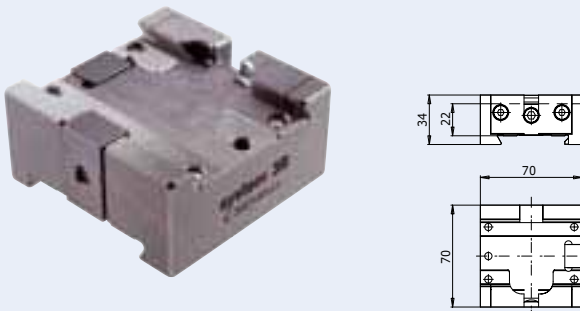

**✓ ICS Slide B (12/22)  
N 460 000**

Support for the ICS clamping elements series B.

- Functional height 12 mm
- Weight 1.9 kg

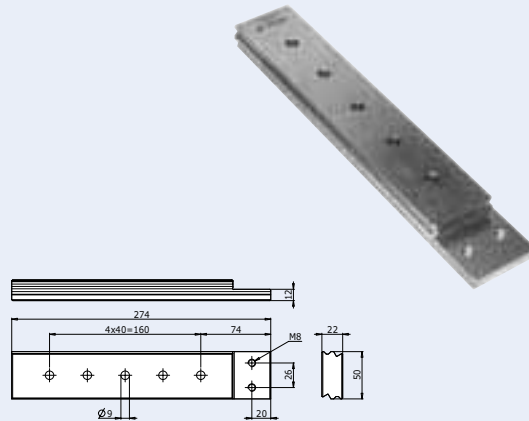

**✓ ICS Slide A  
N 460 700**

Support for the ICS clamping elements series A.

- Adaptation height 7 mm
- Weight 0.6 kg

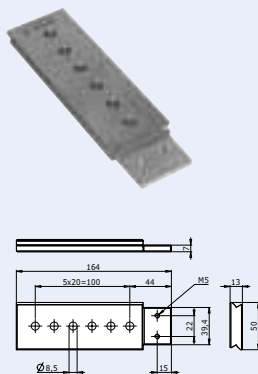

**✓ ICS Slide B  
N 460 100**

Support for the ICS clamping elements series B.

- Adaptation height 12 mm
- Weight 1.0 kg

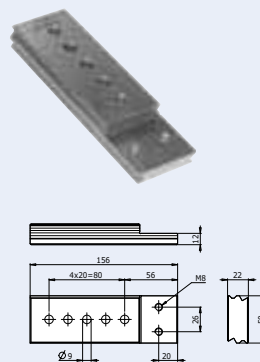

**✓ ICS Slide C  
N 460 300**

Support for the ICS clamping elements series C.

- Adaptation height 22 mm
- Weight 1.2 kg

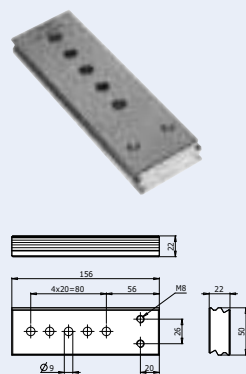

**✓ ICS Support  
"+4"  
N 150 050**

The ICS support "+4" can be fitted between the ICS slides B and C and clamping elements for collision-free clamping.

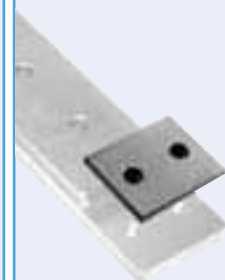

## ICS SLIDE CLAMPING ELEMENTS

The main application of the ICS slide clamps is fixing workpieces of different dimensions in position from two sides.

Recommendation:

Work with opposite elements wherever possible.

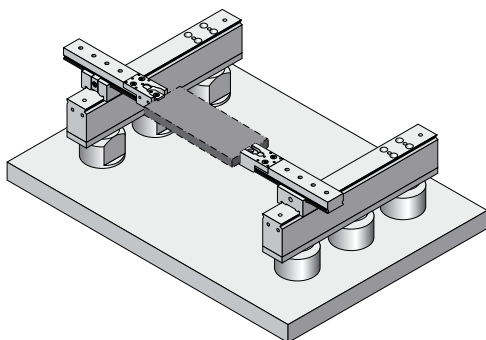

### ✓ ICS Slide clamp 12 C 550 500

The main application of the ICS clamp is fixing workpieces of different dimensions in position from two sides.

- Functional height 12 mm
- Weight 0.9 kg

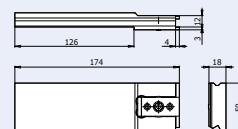

### ✓ ICS Slide clamp 26 C 550 900

The main application of the ICS clamp is fixing workpieces of different dimensions in position from two sides.

- Functional height 26 mm
- Weight 1.3 kg

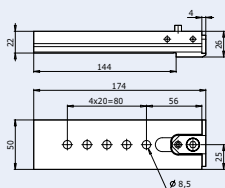

### ✓ ICS Slide clamp 30 C 551 300

The main application of the ICS clamp is fixing workpieces of different dimensions in position from two sides.

- Functional height 30 mm
- Weight 3.0 kg

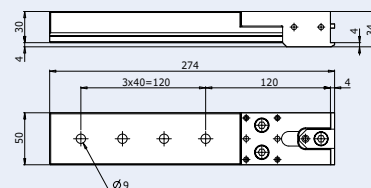
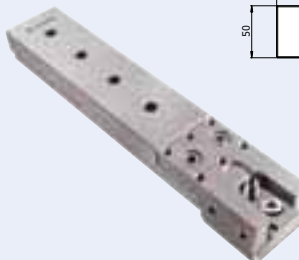

### ICS Slide clamp 30 left C 552 100

The main application of the ICS clamp is fixing workpieces of different dimensions in position from two sides.

- Functional height 30 mm
- Weight 3.0 kg

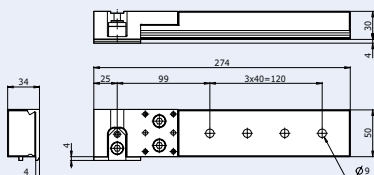
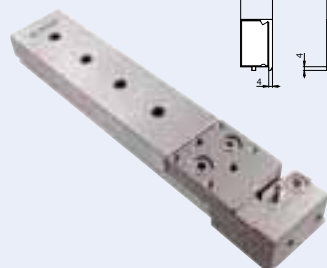

### ICS Slide clamp 30 right C 551 700

The main application of the ICS clamp is fixing workpieces of different dimensions in position from two sides.

- Functional height 30 mm
- Weight 3.0 kg

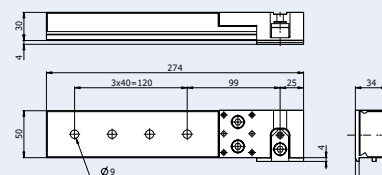
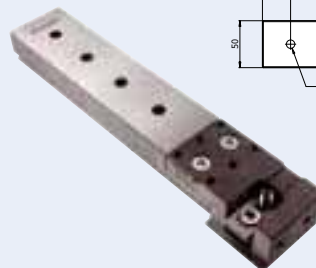

**ICS Slide guide vertical  
C 909 000**

Variable vertical clamping and adjustment of workpieces and electrodes.

- Functional height maximum 180 mm
- Workpiece weight maximum 20 kg
- Weight 5.0 kg

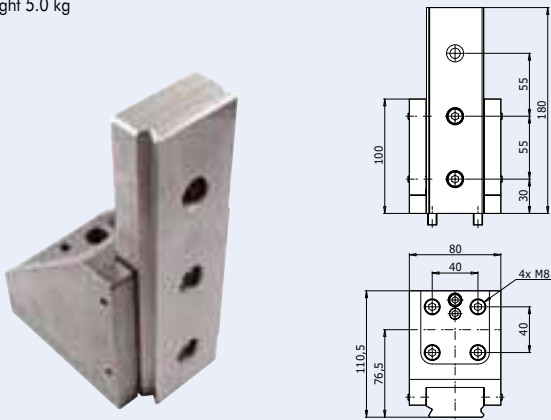

**Base plate  
C 909 060**

Base plate to ICS slide guide vertical C 909 000 for installation on Zeroline machine tables.

- Functional height 12 mm
- Weight 0.9 kg

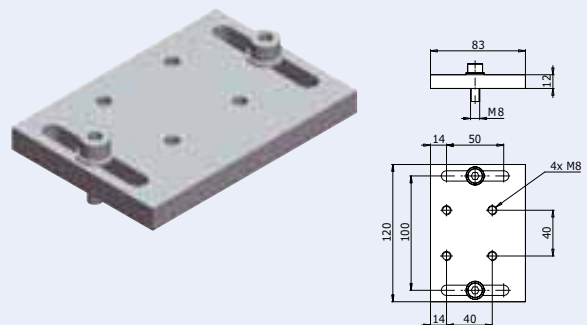

**ICS Pallet  
C 350 100**

The connecting link between the ICS guide rail / ICS beam and elements with hole pattern 40 / 40 mm / M8.

- Functional height 22 mm
- Weight 0.8 kg

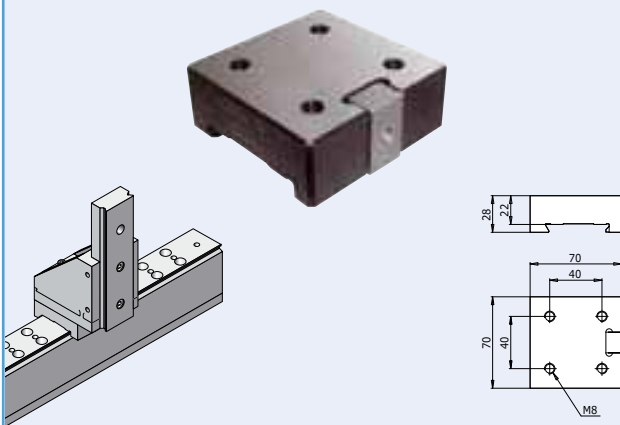

**GPS 70 Chuck  
C 187 900**

Use in combination with C 909 000.

- Weight 2.5 kg

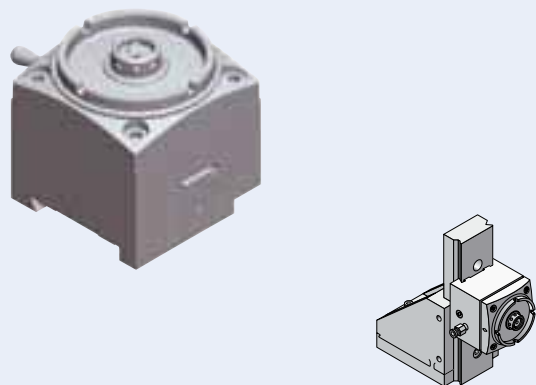

**ICS Pallet 38 rotating  
C 909 020**

ICS pallet with adaptation height 38 mm, top part of the pallet is rotatable.

- Weight 1.4 kg

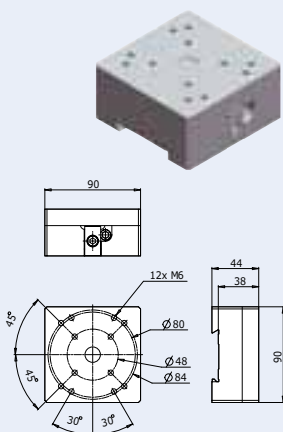

**GPS 70 Chuck  
C 188 750**

Use in combination with C 909 000.

- Weight 1.6 kg

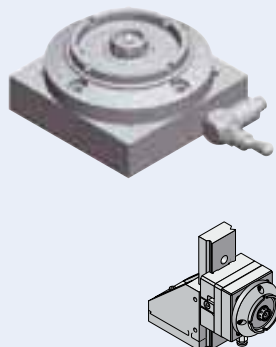

**ICS Pallet 23  
C 909 010**

ICS pallet with adaptation height 23 mm.

- Weight 0.8 kg

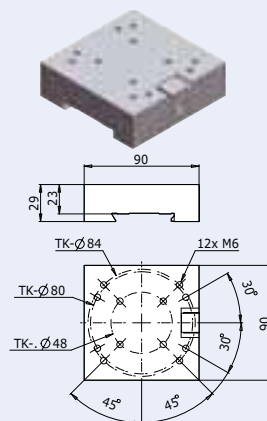

**ICS Adapter A and B/C**

Use in combination with C 909 000 und C 909 010.

- Weight 1.4 kg

**C 456 610**

- Adapter A

**C 456 600**

- Adapter B/C

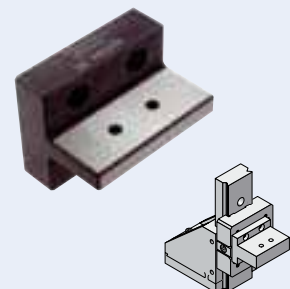

## UNIMATIC PALLET SYSTEM

Reducing setting times and optimising productive times and doing all this with no reduction in machining quality are crucial criteria for ensuring competitiveness.

One promising approach is certainly to enhance flexibility by using pallet systems, specifically universal systems, allowing a fast, flexible response to customer requirements.

It is precisely these demands that are met by the Unimatic Pallet System.

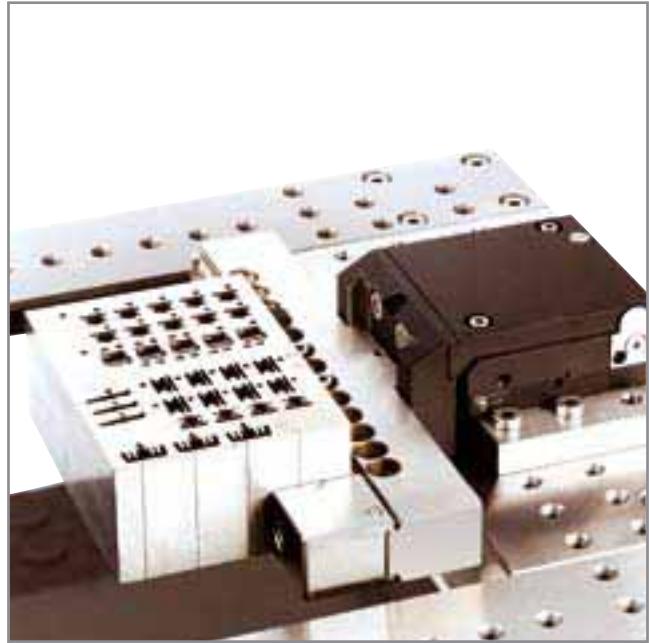

## OVERVIEW OF THE UNIMATIC SYSTEM

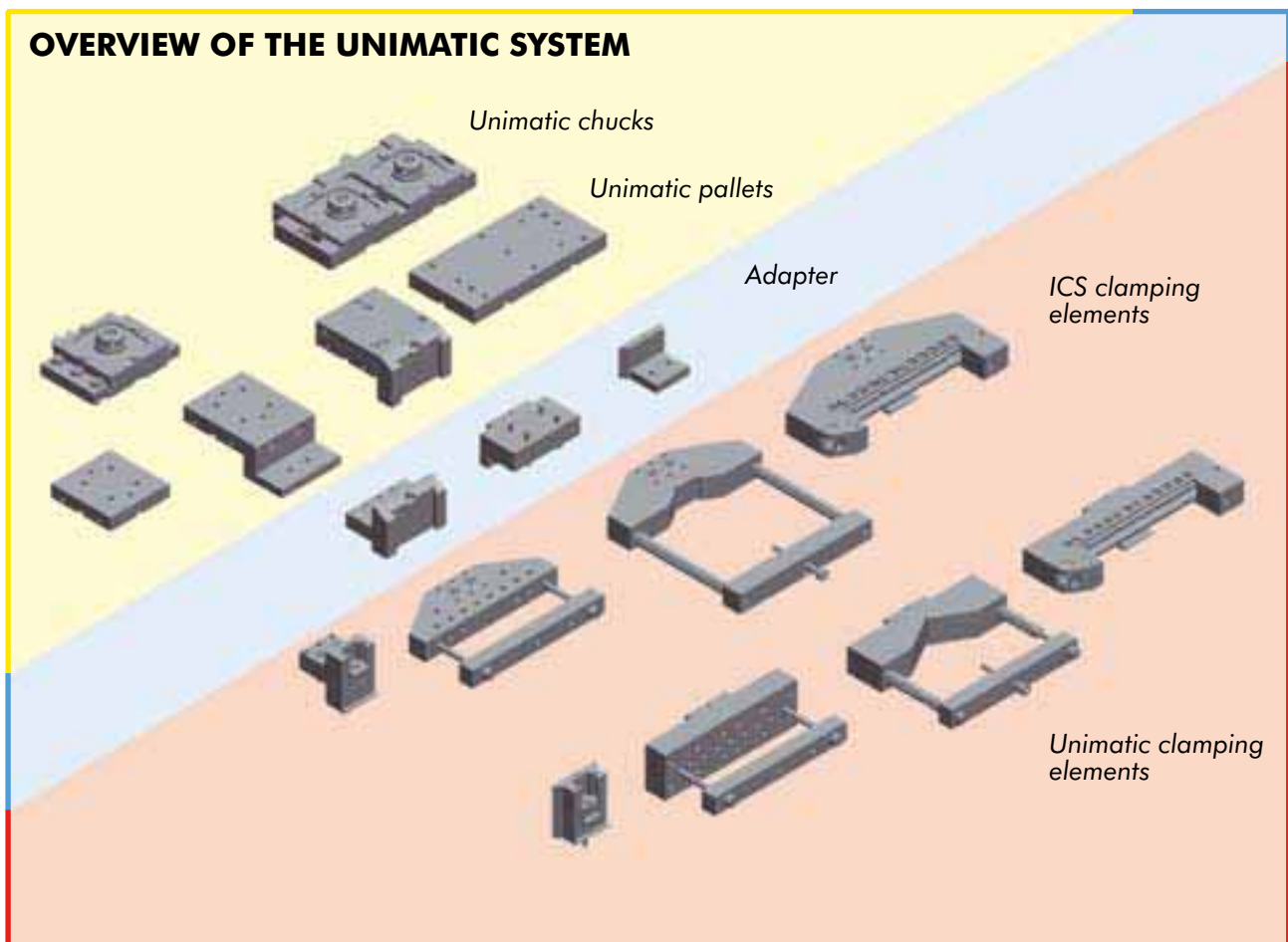

## UNIMATIC CHUCK

is the basic element for manual or automatic feed to the wire EDM machine with palletised workpieces

- ▶ Axial suspension of the X/Y-centring cams in the chuck and ground centering prism in the pallets, ensures maximum repeat and transmission accuracy
- ▶ Unchanging positioning accuracy and high stability even when strong flushing pressure

## 3-AXIS ADJUSTMENT

The workpieces clamped in the clamping elements can be accommodated directly in an adjusting or levelling pallet without further adapters.

- ▶ This allows the adjustment and levelling movements and vertical adjustability to be utilised directly
- ▶ Unsupported clamping of workpieces weighing up to 25 kg with a repeat accuracy of  $\pm 0.002$  mm and a projection of 160 mm

## COMPRESSED-AIR ACTUATION

Pressure 6 bar minimum

Pressure 10 bar maximum

Compressed-air quality: 40  $\mu$ m filtered, dry and de-oiled

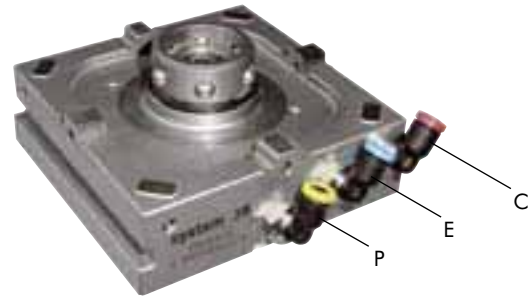

Clamping mechanically with pneumatic release provides maximum operational safety and reliability.

The functions of the compressed air ports are as follows:

P = releasing / clamping

E = ventilation

C = support cleaning / presence check

## Unimatic clamping function

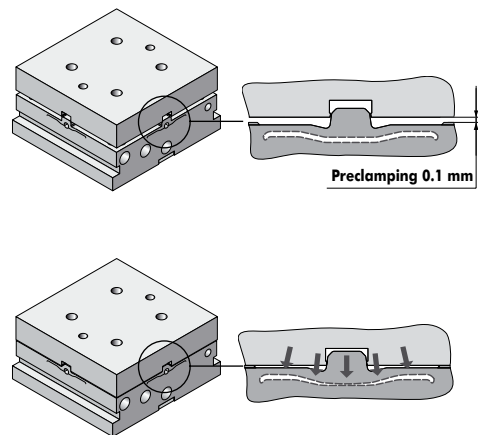

### ✓ Unimatic Chuck C 950 000

Manual and automatic palletizing of work carriers.

- Functional height 28 mm
- Clamping force 5000 N
- Weight 1.9 kg

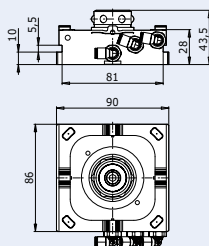

### ✓ Unimatic Twin Chuck C 950 070

Manual and automatic palletizing of work carriers with workpieces >25 kg.

- Functional height 28 mm
- Clamping force 10000 N
- Weight 2.8 kg

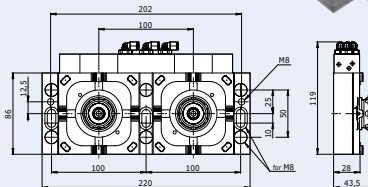
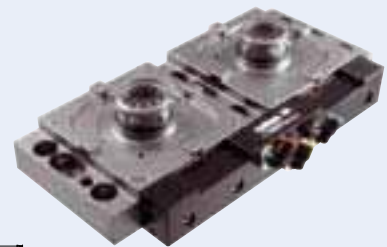

### Unimatic Brackets C 950 0XX

The Unimatic brackets for mounting the chuck C 950 000 on the zeroline table are machine-dependent.

*Note: Please use the selection tables on our webpage ([www.system3r.com](http://www.system3r.com)) to determine the appropriate Unimatic bracket or state the make of machine and type when ordering.*



### Set Unimatic Basic equipment S 206 301

consisting of:

|           |                            |    |
|-----------|----------------------------|----|
| C 950 000 | Unimatic Chuck             | x1 |
| C 960 500 | Unimatic Control unit      | x1 |
| C 960 710 | Unimatic Protection pallet | x1 |
| C 950 0XX | Unimatic Bracket*          | x1 |

\* When ordering, please state the machine type to allow us to determine the Unimatic brackets.



### ✓ Set Unizero Go! S 112 050

consisting of:

|           |                           |    |
|-----------|---------------------------|----|
| C 950 000 | Unimatic Chuck            | x1 |
| C 950 170 | Unimatic Adjusting pallet | x1 |
| C 960 110 | Unimatic Vice 10-30       | x1 |
| C 190 820 | Air-pistol valve          | x1 |
| E 100 007 | Set hexagon Allen wrench  | x1 |
| C 950 0xx | Unimatic Brackets*        | x1 |

Set packed in case

\* When ordering, please state the machine type to allow us to determine the Unimatic brackets.

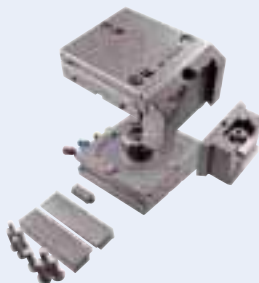

### ✓ Set Unizero Go2! S 112 060

consisting of:

|           |                                |    |
|-----------|--------------------------------|----|
| C 950 000 | Unimatic Chuck                 | x1 |
| C 950 170 | Unimatic Adjusting pallet      | x1 |
| C 960 040 | Unimatic V-block flange 30/200 | x1 |
| C 190 820 | Air-pistol valve               | x1 |
| E 100 007 | Set hexagon Allen wrench       | x1 |
| C 950 0xx | Unimatic Brackets*             | x1 |

Set packed in case

\* When ordering, please state the machine type to allow us to determine the Unimatic brackets.

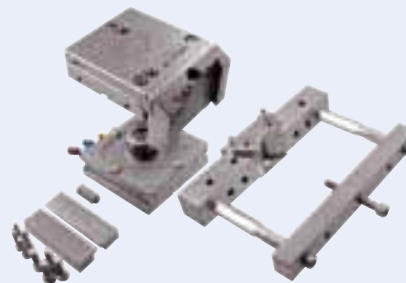

### ✓ Unimatic Levelling pallet C 950 150

Levelling pallet with dovetail guide adaptation.

- Adjustment range approx.  $\pm 1.0$  mm for all three axes
- Functional height 59 mm, Unimatic pallet placed onto Unimatic chuck
- Weight 2.5 kg

#### C 951 150

- Ready for use for automation with assembled code tag and pins.

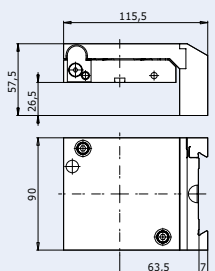

### ✓ Unimatic Adjusting pallet C 950 170

Adjusting pallet with dovetail guide adaptation.

- Adjustment range  $\pm 0.2$  mm for all three axes
- Functional height 59 mm, Unimatic pallet placed onto Unimatic chuck
- Weight 2.5 kg

#### C 951 170

- Ready for use for automation with assembled code tag and pins.

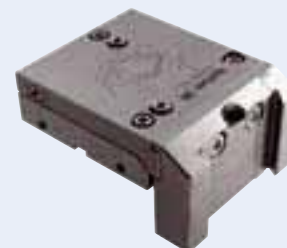
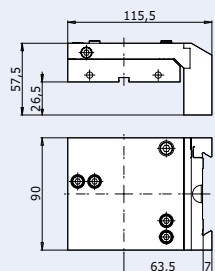

**Unimatic Levelling pallet ICS B  
C 950 180**

Levelling pallet with ICS B adaptation.

- Adjustment range approx.  $\pm 1.0$  mm for all three axes
- Functional height 59 mm, Unimatic pallet placed onto Unimatic chuck
- Adaptation height 12 mm
- Weight 2.5 kg

**C 951 180**

- Ready for use for automation with assembled code tag and pins.

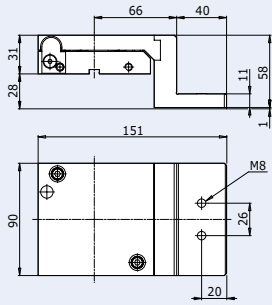

**Unimatic Adjusting pallet ICS B  
C 950 190**

Adjusting pallet with ICS B adaptation.

- Adjustment range  $\pm 0.2$  mm for all three axes
- Functional height 59 mm, Unimatic pallet placed onto Unimatic chuck
- Adaptation height 12 mm
- Weight 2.5 kg

**C 951 190**

- Ready for use for automation with assembled code tag and pins.

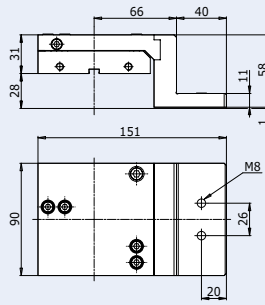

**✓ Unimatic Pallet  
C 950 100**

Pallet used as fixture carrier.

- The overall height of the Unimatic chuck C 950 000 together with the Unimatic pallet C 950 100 is 46 mm
- Functional height 18 mm
- Weight 0.9 kg

**C 951 100**

- Ready for use for automation with assembled code tag and pins.

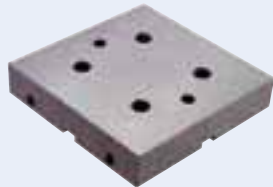
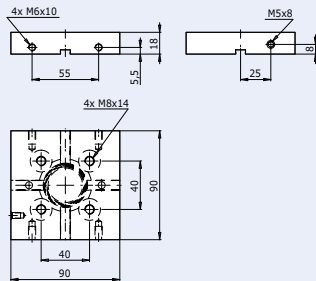

**✓ Unimatic Pallet A  
C 950 120**

Support for ICS clamping elements series A.

- Functional height 21 mm (A)
- Adaptation height 7 mm
- Weight 1.6 kg

**C 951 120**

- Ready for use for automation with assembled code tag and pins.

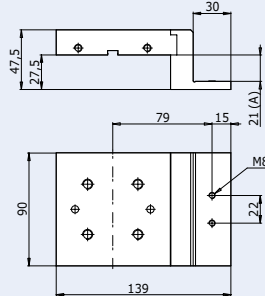

**✓ Unimatic Pallet B  
C 950 130**

Support for ICS clamping elements series B.

- Functional height 16 mm (B)
- Adaptation height 12 mm
- Weight 1.9 kg

**C 951 130**

- Ready for use for automation with assembled code tag and pins.

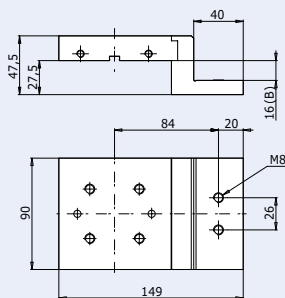

**✓ Unimatic Pallet C  
C 950 140**

Support for ICS clamping elements series C.

- Functional height 6 mm (C)
- Adaptation height 22 mm
- Weight 2.0 kg

**C 951 140**

- Ready for use for automation with assembled code tag and pins.

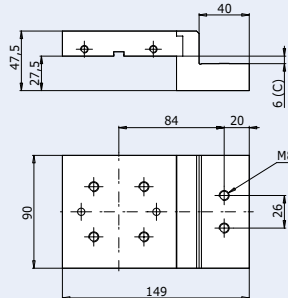

### Unimatic Twin pallet

Unimatic Twin Pallets are designed and supplied customer-specifically in accordance with requirements.



### Set Unimatic Clamping frame S 149 500

The Unimatic clamping frame with clamping range of 200 x 220 mm is the ideal element for multiple clamping of small parts.

The workpieces can be clamped at zeroline or collision-free at +4 mm.

It is advisable to support the clamping frame with the two clamps

C 552 640 for workpiece weights exceeding 5 kg.

- Functional dimensions clamping range 200 x 220 mm
- Weight 14 kg

consisting of:

- |           |                         |    |
|-----------|-------------------------|----|
| C 950 600 | Clamping frame 200/220  | x1 |
| C 950 610 | Clamping bar 22/220     | x1 |
| C 950 620 | Clamping bar 35/220     | x1 |
| C 552 640 | Standard clamp 150      | x2 |
| S 149 510 | Set screws/lips/bracket | x1 |

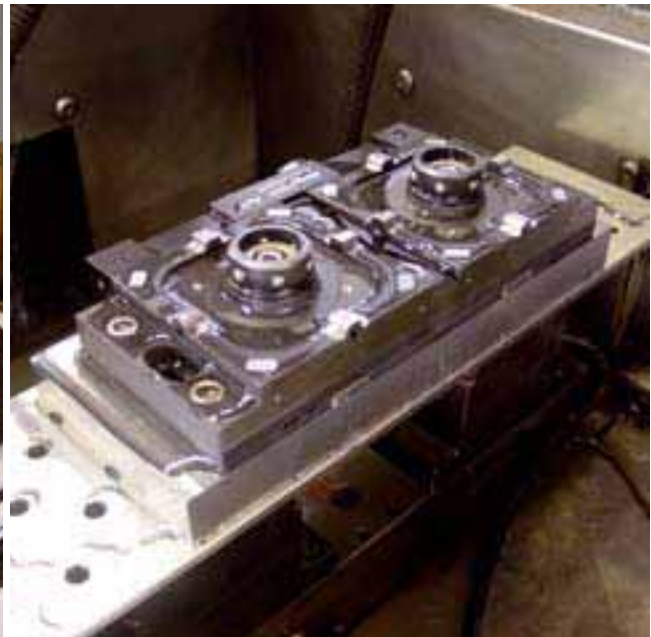
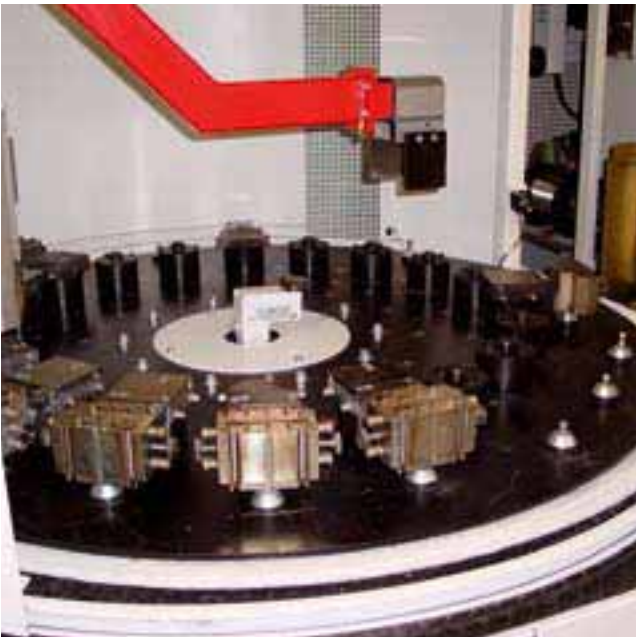
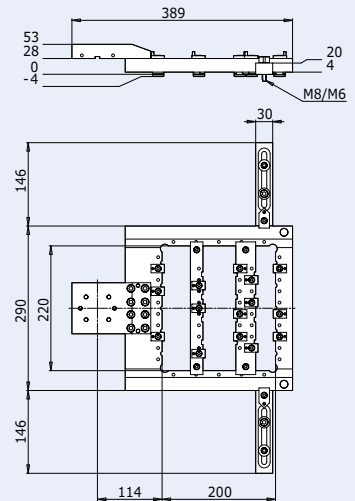
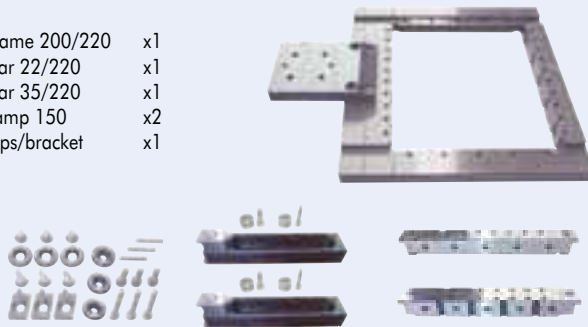



✓ Unimatic Reference pallet  
C 960 450

Measuring and inspection element.

- Functional height 18 mm
- Indexing 4 x 90°
- Accuracy repetition 0.001 mm / transfer  $\pm 0.002$  mm on 160 mm
- Positioning of reference hole 160  $\pm 0.002$  mm to pallet centre
- Weight 2.7 kg

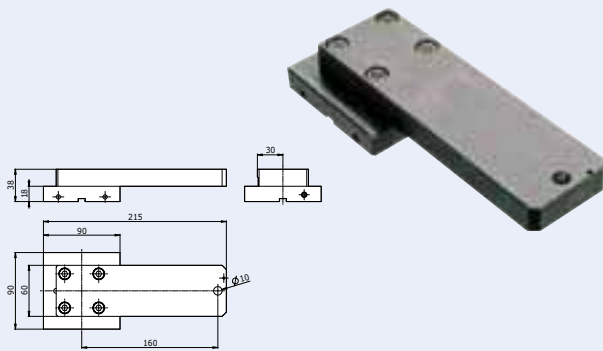

Unimatic Force checking unit  
C 960 430

Force checking on the Unimatic chuck.

- Weight 0.7 kg



✓ Unimatic Protection pallet  
C 960 710

Protection of ball cage and X/Y-reference elements of the Unimatic chuck.

- Functional height 20 mm
- Weight 0.4 kg

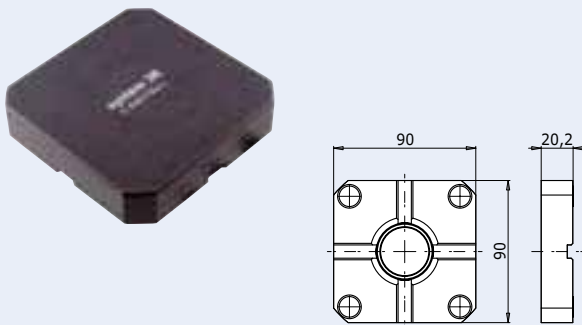

✓ Unimatic Control unit (1-fold)  
C 960 500

Pneumatic control for Unimatic chuck.

- Weight 0.4 kg



✓ Unimatic Control unit (2-fold)  
S 190 520

Individual actuation of two Unimatic chucks.

- Weight 4.2 kg

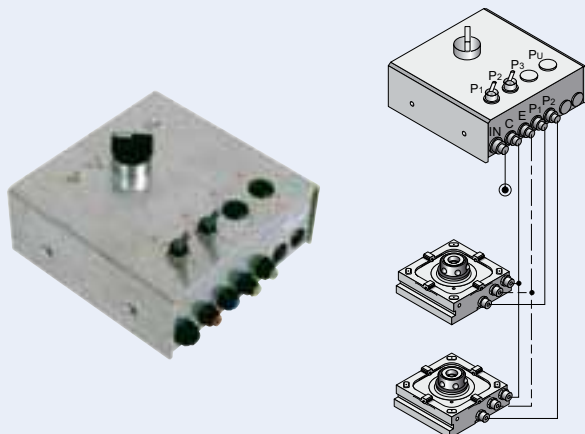

✓ Set Unimatic Revision  
S 190 900

Wear parts set for Unimatic chucks C 950 000 and C 950 070.



## ICS CLAMPING ELEMENTS

The diverse range of clamping elements included in the two ICS and Unimatic product lines offer an optimum solution for virtually any clamping problem.

The corresponding adapters allow the user to freely combine ICS, Unimatic and also System 3R clamping elements and clamping systems.

### ICS A, B AND C

The right clamping element for every large workpiece.

- ▶ Series A / for small workpieces up to 3 kg
- ▶ Series B / for medium-size workpieces up to 10 kg
- ▶ Series C / for large workpieces over 10 kg

Adjusting screws can be used to adjust in the range of 0.05 mm on all ICS clamping elements.

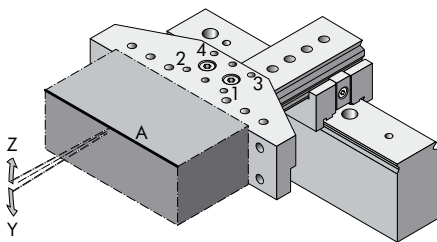

#### Correction, Line A

Tightening 1 and 2 corrects line A in direction Z shown by the arrow.

Tightening 3 and 4 corrects line A in direction Y shown by the arrow.

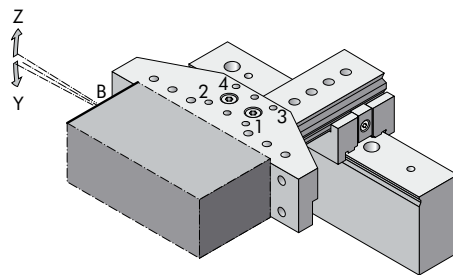

#### Correction, Line B

Tightening 2 and 4 corrects line B in direction Z shown by the arrow.

Tightening 1 and 3 corrects line B in direction Y shown by the arrow.

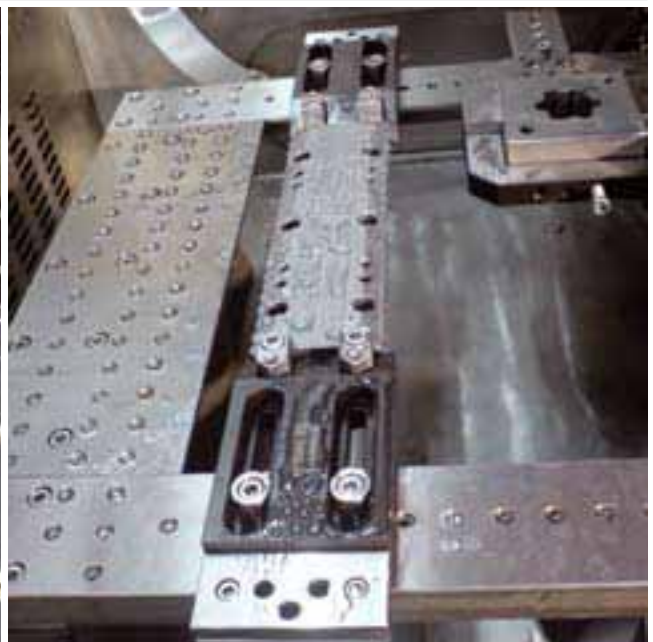
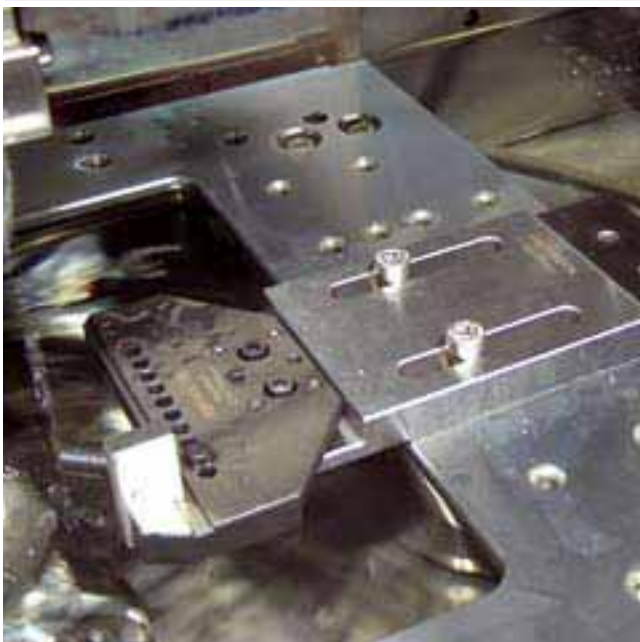

**SERIES A**

Application: Small parts up to 3 kg  
 Adaptation height: 7 mm  
 Height of the clamping element: 13 mm  
 Mounting: 2 screws M5  
 spacing 22 mm  
 tightening torques 5 Nm

Adaptation to:  
 ICS: All elements with ICS A adaptation  
 Unimatic: C 950 120 or via C 950 510  
 on C 950 150 / C 950 170

✓ ICS Mecavice A (0-75)  
**C 577 250**

Workpiece holder with guide for horizontal parallel clamping.

- Functional height 13 mm
- Clamping range 0 – 75 mm
- Maximum workpiece weight 1 kg
- Maximum workpiece dimensions 75 x 75 x 20 mm
- Weight 0.5 kg

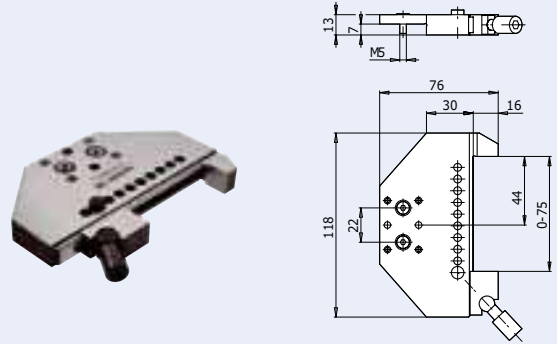

✓ ICS Clamping head A (7/50)  
**C 550 650**

The main application of the ICS clamp is fixing workpieces of different dimensions in position from two sides.

- Clamping range 0 - 10 mm
- Maximum workpiece weight 3 kg – not for overhung clamping!
- Weight 0.3 kg

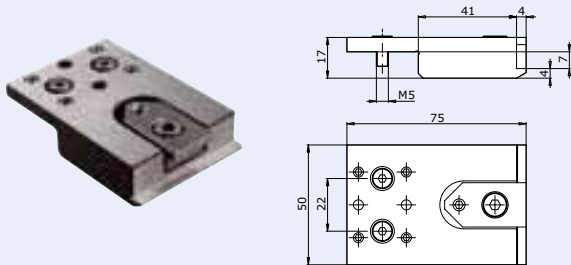

ICS V-block A 45/45  
**C 599 450**

Workpiece carrier for round and cubic parts.

- Functional height 13 mm
- Clamping range round or cubic up to 45 mm
- Maximum workpiece weight 3 kg
- Maximum workpiece dimensions Ø45 mm or 45 x 45 mm
- Weight 0.4 kg

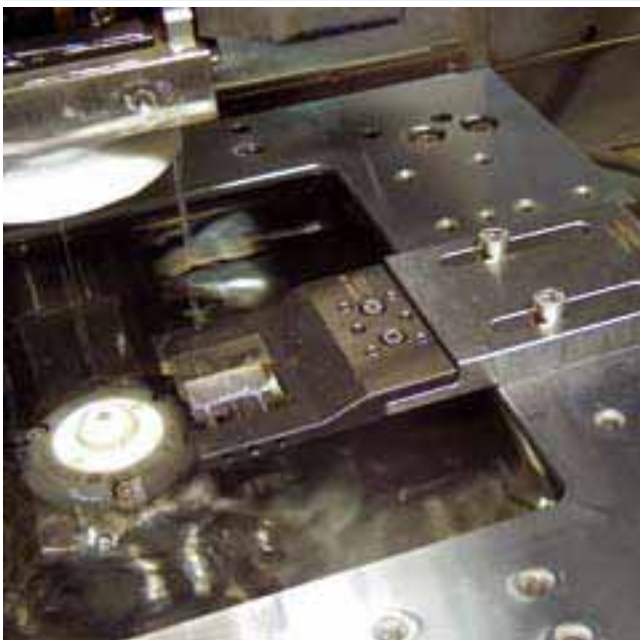
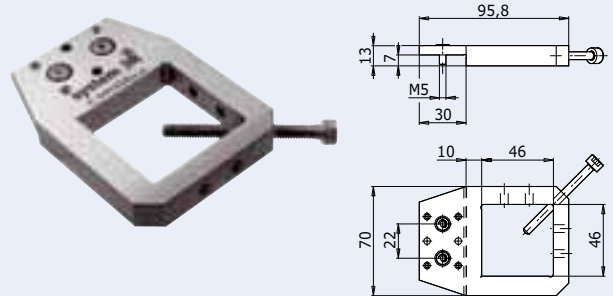

✓ ICS Double clamp A (5/80)  
C 550 670

Clamp for holding thin plates with support lips at zero height. A 4 mm thin shim can be inserted between the adaptation faces for collision free clamping.

- Clamping range 0 - 5 mm
- Maximum workpiece weight 1 kg - overhung clamping
- Weight 0.4 kg

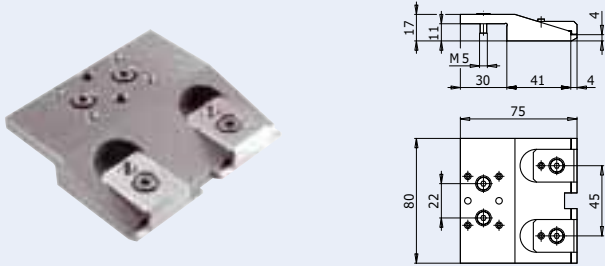

✓ ICS Side clamp A (20-40)  
C 577 200

Collateral clamping of rectangular or square small workpieces from 20 to 40 mm width.

- Functional height 6,5 mm
- Clamping range 20 - 40 mm
- Maximum workpiece weight 0.5 kg
- Weight 0.5 kg

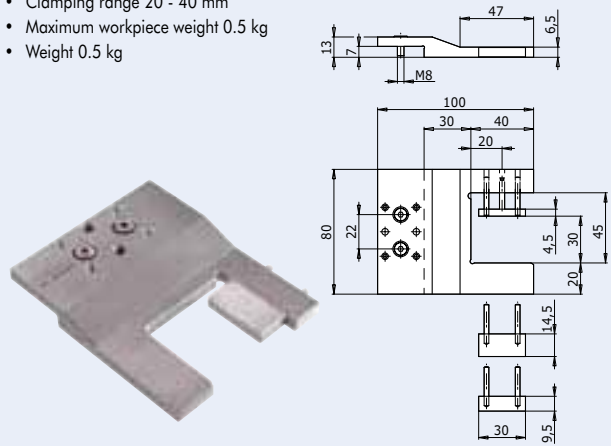

✓ ICS Flange A (7/120)  
C 641 900

Support for the lateral mounting of workpiece.

- Functional height 7 mm
- Maximum workpiece weight 1 kg
- Maximum workpiece dimensions width 100 mm max.
- Weight 0.5 kg

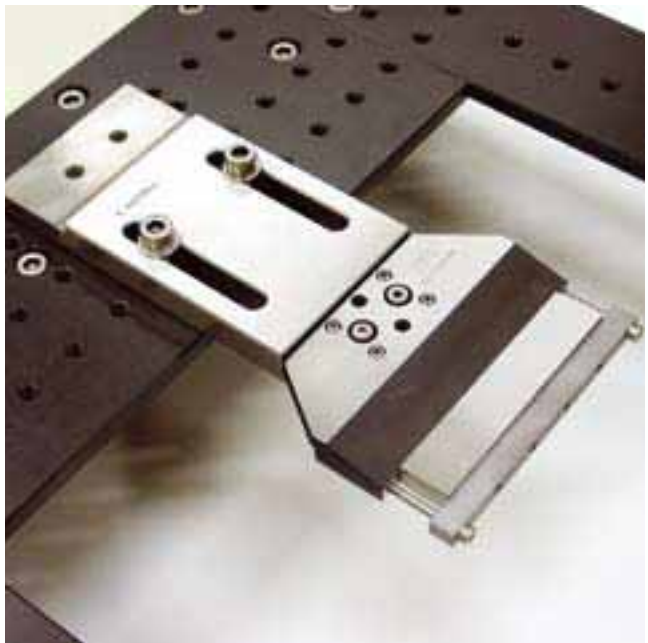
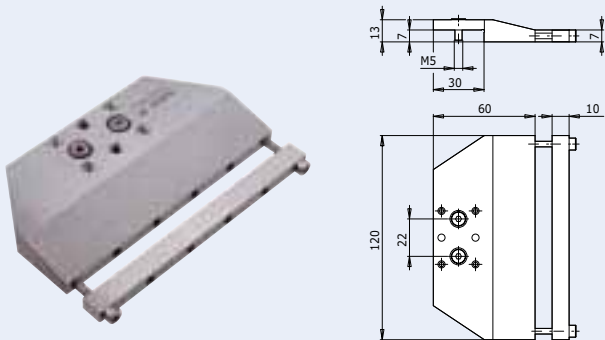

✓ ICS Clamping frame A  
C 619 660

Carrier for flat round or cubic workpieces up to 80x80 mm.

- Functional height 13 mm
- Clamping range round or cubic up to 80 mm / maximum workpiece height 12 mm
- Maximum workpiece weight 1.5 kg
- Maximum workpiece dimensions  $\varnothing$  80 mm or 80x80 mm
- Weight 0.9 kg

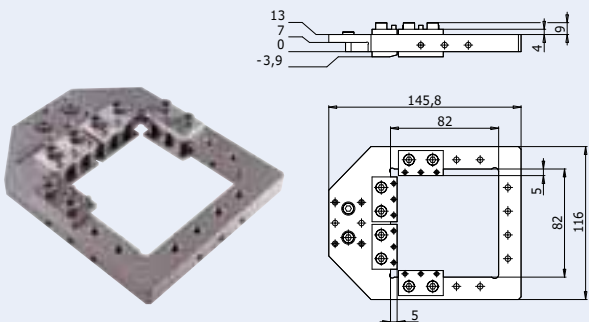

✓ ICS Clamping bar to clamping frame A  
C 619 670

Clamping bar to use with ICS clamping frame A C 619 660.

- Dimensions 88 x 20 x 26 mm
- Overall height 26 mm (incl. support lips and clamping lips)
- Weight 0.25 kg

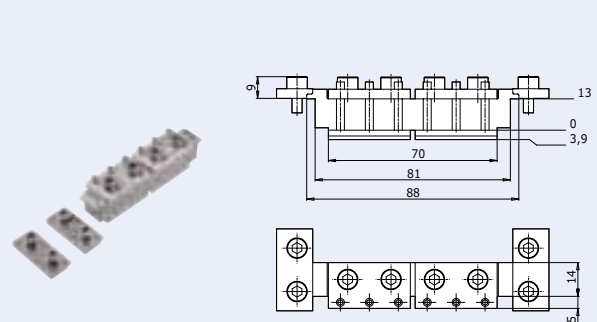

**SERIES B**

Application: Medium-sized workpieces up to 10 kg  
 Adaptation height: 12 mm  
 Mounting: 2 screws M8  
 spacing 26 mm  
 tightening torques 20 Nm

Adaptation to:  
 ICS: All elements with ICS B adaptation  
 Unimatic: C 950 130 or  
 via C 950 530  
 on C 950 150 / C 950 170  
 and C 950 180 / C 950 190

✓ ICS Clamping head B (12/50)  
**C 552 300**

The main application of the ICS clamp is fixing workpieces of different dimensions.

- Clamping range 0 - 20 mm
- Maximum workpiece weight 10 kg – not for overhung clamping!
- Weight 0.5 kg

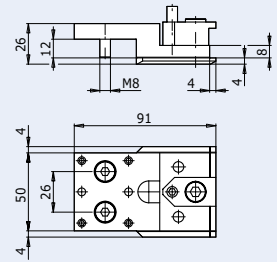

✓ ICS Clamping head B right (12/50)  
**C 552 400**

The main application of the ICS clamp is fixing workpieces of different dimensions.

- Clamping range 0 - 20 mm
- Maximum workpiece weight 10 kg – not for overhung clamping!
- Weight 0.5 kg

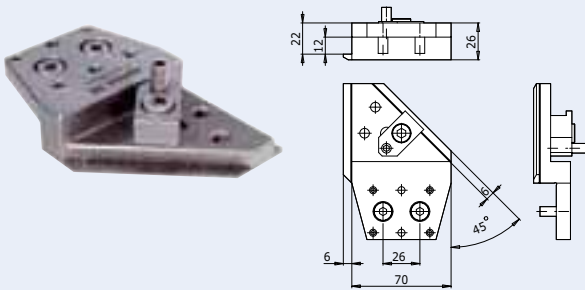

✓ ICS Clamping head B left (12/50)  
**C 552 500**

The main application of the ICS clamp is fixing workpieces of different dimensions.

- Clamping range 0 - 20 mm
- Maximum workpiece weight 10 kg – not for overhung clamping!
- Weight 0.5 kg

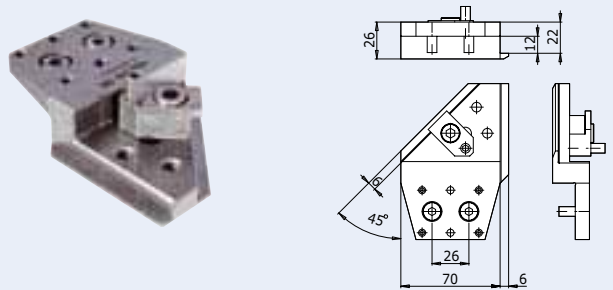

✓ ICS Vice B 0-20  
C 573 550

Workpiece carrier with guide for vertical parallel clamping, with 2 clamping jaws.

- Functional height 20 mm
- Clamping range 0 - 20 mm
- Maximum workpiece weight 1 kg
- Maximum workpiece dimensions 20 x 50 x 50 mm
- Weight 0.4 kg

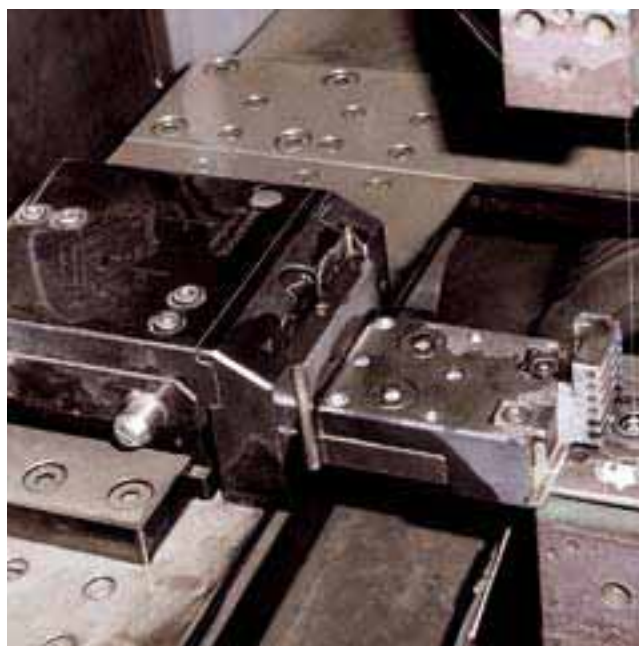
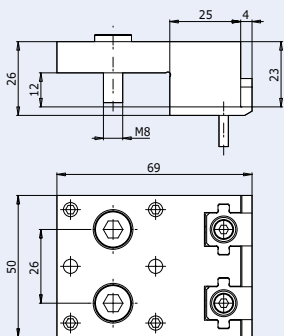

✓ ICS Vice B 10-30  
C 574 150

Workpiece carrier with guide for vertical parallel clamping.

- Functional height 30 mm
- Clamping range 0 - 30 mm
- Maximum workpiece weight 3 kg
- Maximum workpiece dimensions 30 x 90 x 90 mm
- Weight 0.6 kg

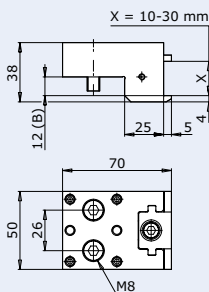

✓ ICS Mecavice B 0-150  
C 577 350

Workpiece holder with guide for horizontal parallel clamping.

- Functional height 22 mm
- Clamping range 0 - 150 mm
- Maximum workpiece weight 4 kg
- Maximum workpiece dimensions 150 x 120 x 22 mm
- Weight 1.6 kg

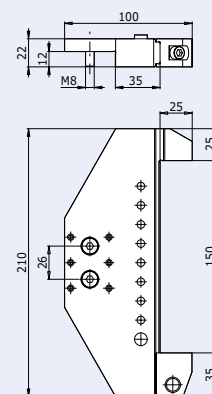

✓ ICS Mecavice B 0-175  
C 577 370

Workpiece holder with guide for horizontal parallel clamping.

- Functional height 30 mm
- Clamping range 0 - 175 mm
- Maximum workpiece weight 10 kg
- Maximum workpiece dimensions 100 x 120 x 175 mm
- Weight 3.7 kg

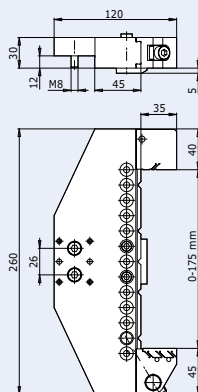

Vice jaw set  
S 150 100

Jaw set for Mecavice B and Unimatic vice with guide for horizontal parallel clamping.

- Functional height 30 mm
- Clamping depth jaw 18 mm
- Maximum workpiece weight 5 kg
- Weight 0.4 kg

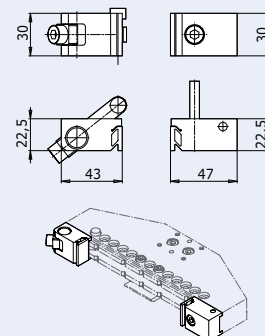
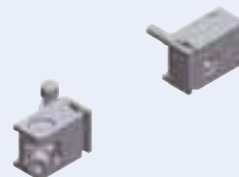

**ICS V-block vice B  $\varnothing$ 10-100  
C 596 050**

Workpiece holder for round parts.

- Functional height 30 mm
- Clamping range  $\varnothing$ 10 – 100 mm
- Maximum workpiece weight 10 kg
- Maximum workpiece dimensions  $\varnothing$ 100 x 150 mm
- Weight 4.0 kg

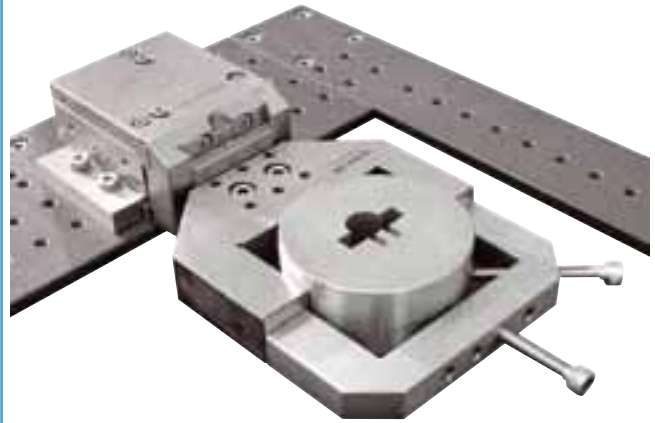
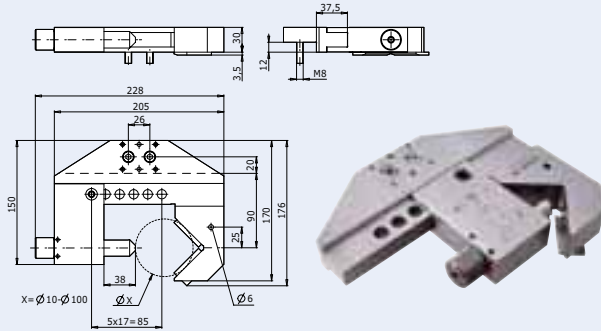

**✓ ICS Flange B (26/200)  
C 642 050**

Support for the lateral mounting of workpiece.

- Functional height 26 mm
- Maximum workpiece weight 10 kg
- Maximum workpiece dimensions quadratic 120 x 120 mm / rectangular 120 x 150 mm
- Weight 2.1 kg

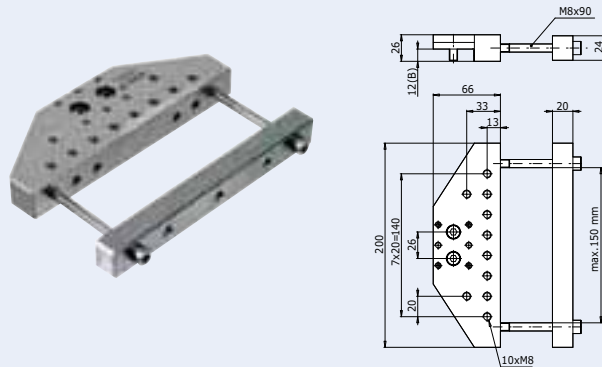

**✓ ICS V-block B 50/50  
C 596 650**

Workpiece carrier for round and cubic parts.

- Functional height 22 mm
- Clamping range round or cubic 10 – 50 mm
- Maximum workpiece weight 3 kg
- Maximum workpiece dimensions  $\varnothing$ 50 mm or 50 x 50 mm
- Weight 0.7 kg

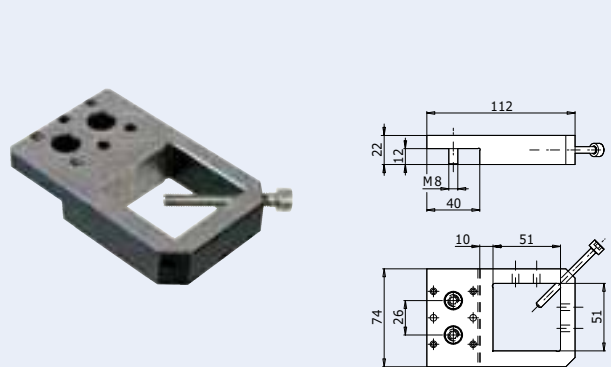

**✓ ICS V-block B 100/100  
C 597 250**

Workpiece carrier for round and cubic parts.

- Functional height 30 mm
- Clamping range round or cubic 75 – 100 mm
- Maximum workpiece weight 8 kg
- Maximum workpiece dimensions  $\varnothing$ 100 mm or 100 x 100 mm
- Weight 2.7 kg

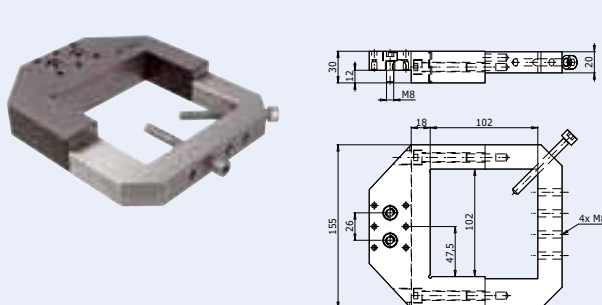

**✓ ICS V-block B 100 - 150  
C 597 550**

Workpiece holder for round parts.

- Functional height 30 mm
- Clamping range  $\varnothing$ 100 – 150 mm
- Maximum workpiece weight 10 kg
- Maximum workpiece dimensions  $\varnothing$ 150 x 80 mm
- Weight 3.4 kg

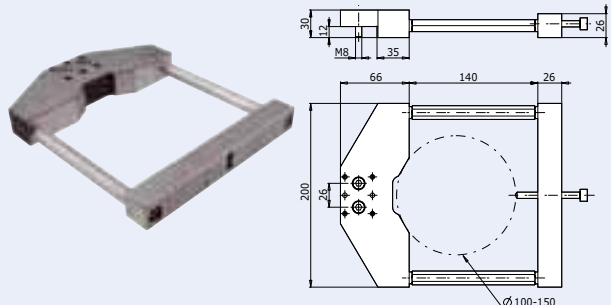

**SERIES C**

Application: Large workpieces over 10 kg  
 Adaptation height: 22 mm  
 Mounting: 2 screws M8  
 spacing 26 mm  
 tightening torques 20 Nm

Adaptation to:  
 ICS: All elements with ICS C adaptation  
 Unimatic: C 950 140 or via C 950 550  
 on C 950 150 / C 950 170

✓ ICS Mecavice C 0-100  
**C 575 600**

Workpiece holder with guide for horizontal parallel clamping.  
 • Functional height 50 mm  
 • Clamping range 0 – 100 mm  
 • Maximum workpiece weight 12 kg  
 • Maximum workpiece dimensions 100 x 120 x 130 mm  
 • Weight 2.7 kg

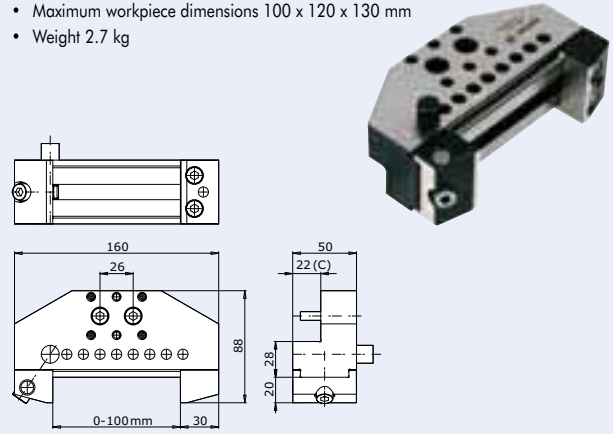

✓ ICS Vices C 50-100 (10-40 / 26-60 / 50-100)

Workpiece carrier with guide for vertical parallel clamping.

**C 574 550**

- Clamping range 10 – 40 mm
- Functional height 40 mm
- Maximum workpiece weight 4 kg
- Maximum workpiece dimensions 40x100x100 mm
- Weight 0.7 kg

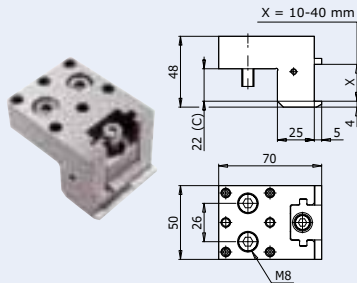

**C 575 050**

- Clamping range 26 – 60 mm
- Functional height 60 mm
- Maximum workpiece weight 6 kg
- Maximum workpiece dimensions 60x100x100 mm
- Weight 0.9 kg

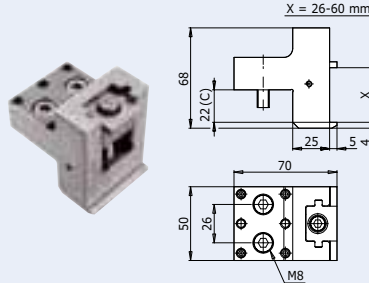

**C 575 550**

- Clamping range 50 – 100 mm
- Functional height 100 mm
- Maximum workpiece weight 8 kg
- Maximum workpiece dimensions 100x100x100 mm
- Weight 1.2 kg

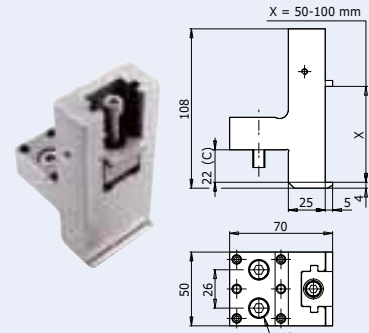

**ICS Flange C (50/200)**  
**C 642 150**

Support for the lateral mounting of workpiece.

- Functional height 50 mm
- Maximum workpiece weight 20 kg
- Maximum workpiece dimensions quadratic 120 x 120 mm / rectangular 120 x 200 mm
- Weight 2.0 kg

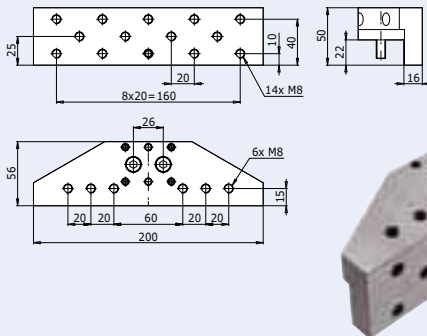

**ICS Flange C (50/300)**  
**C 642 160**

Support for the lateral mounting of workpiece.

- Functional height 50 mm
- Maximum workpiece weight 25 kg
- Maximum workpiece dimensions quadratic 150 x 150 mm / rectangular 150 x 300 mm
- Weight 3.3 kg

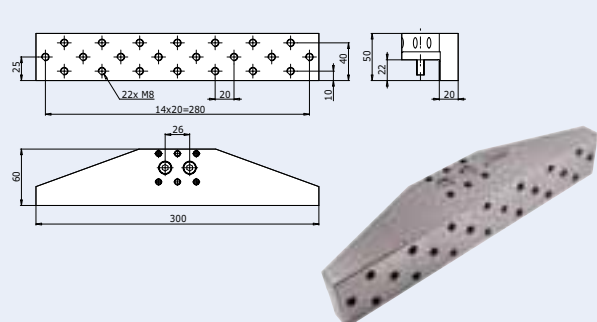



**THE UNIMATIC CLAMPING ELEMENTS**

are vertically adjustable in the dovetail guide. It is important that the slides of the clamping elements always engage at least 20 mm in the guide.

The Clamping Elements are clamped by means of the two M5 screws at the side. Very little clamping force is required for achieving a very stable connection.

Tightening torque: max. 5 Nm

**Important:**

Clamp with both screws only when the slide has engaged over the entire length of the guide.

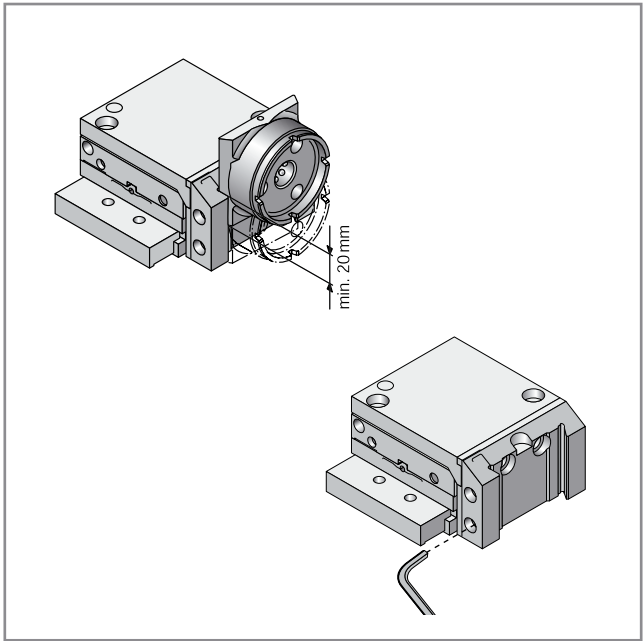

**✓ Unimatic Flange 30/70  
C 960 010**

Support for the lateral mounting of workpiece.

- Functional height 30 mm
- Maximum workpiece weight 12 kg
- Maximum workpiece dimensions 150 x 100 x 100 mm
- Weight 0.3 kg

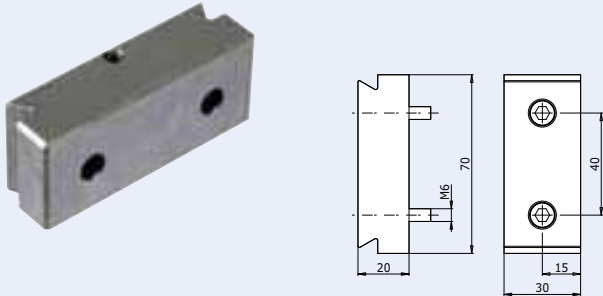

**✓ Unimatic Flange 54/54  
C 960 030**

Support for the lateral mounting of workpiece.

- Functional height 54 mm
- Maximum workpiece weight 15 kg
- Maximum workpiece dimensions 150 x 120 x 100 mm
- Weight 0.3 kg

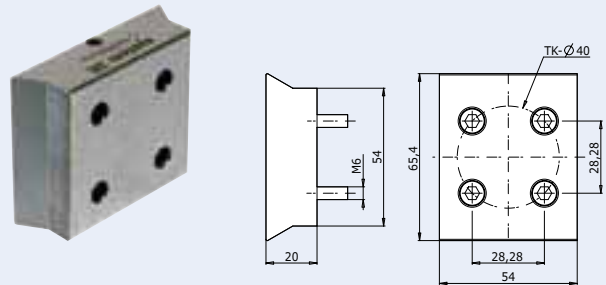

**✓ Unimatic Flange 30/200  
C 960 050**

Support for the lateral mounting of workpiece.

- Functional height 30 mm
- Maximum workpiece weight 15 kg
- Maximum workpiece dimensions 100 x 120 x 150 mm
- Weight 1.5 kg

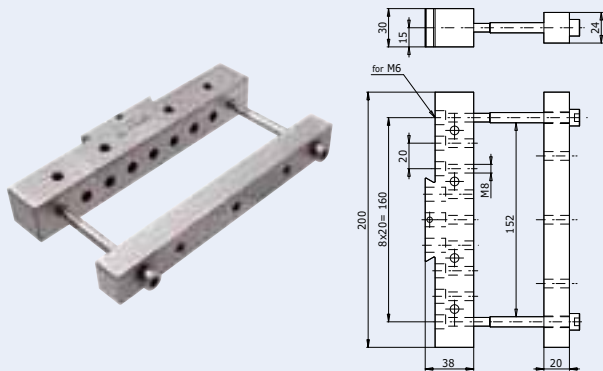

**✓ Unimatic Flange 60/200  
C 960 060**

Support for the lateral mounting of workpiece.

- Functional height 60 mm
- Maximum workpiece weight 20 kg
- Maximum workpiece dimensions 100 x 130 x 200 mm
- Weight 2.9 kg

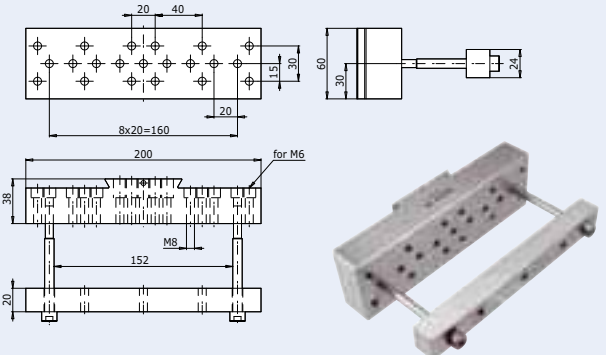

## THE UNIMATIC VICES

are suitable for clamping parallel and rectangular-machined workpieces. The guided clamping jaw ensures clean and neat parallel clamping.

Tightening torque of the clamping screw:  
max. 9 Nm

The levelling and adjusting pallets include adjustment screws for vertical setting of the clamping elements.  
(Item no S 206 310)

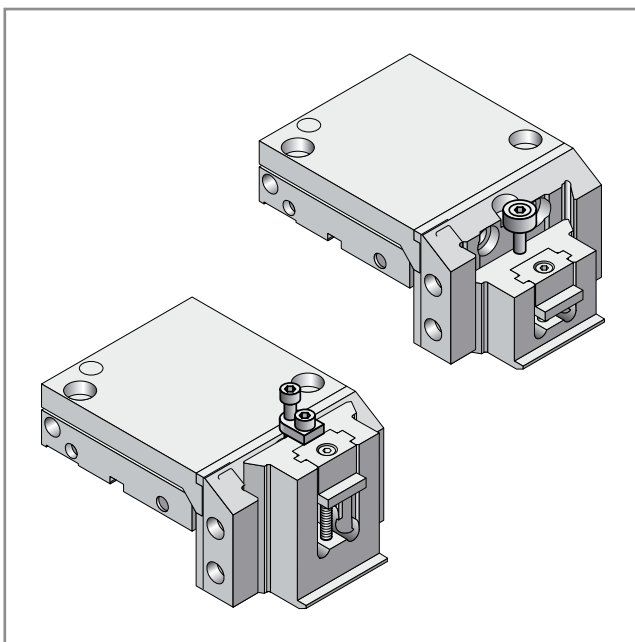

### ✓ Unimatic Vice index 0-55 C 960 100

Workpiece carrier, 90° indexing, for parallel clamping of round and square parts.

- Functional height 55 mm
- Clamping range square 0 – 55 mm / round  $\varnothing 10 - 45$  mm
- Maximum workpiece weight 4 kg
- Weight 0.9 kg

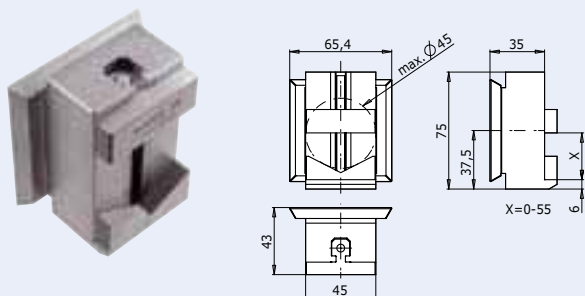

### ✓ Unimatic Vice 10-30 C 960 110

Workpiece carrier with guide for vertical parallel clamping.

- Functional height 30 mm
- Clamping range 10 – 30 mm
- Maximum workpiece weight 3 kg
- Maximum workpiece dimensions 30 x 100 x 120 mm
- Weight 0.5 kg



### ✓ Unimatic Vice 20-60 C 960 120

Workpiece carrier with guide for vertical parallel clamping.

- Functional height 60 mm
- Clamping range 20 – 60 mm
- Maximum workpiece weight 6 kg
- Maximum workpiece dimensions 60 x 100 x 120 mm
- Weight 0.8 kg

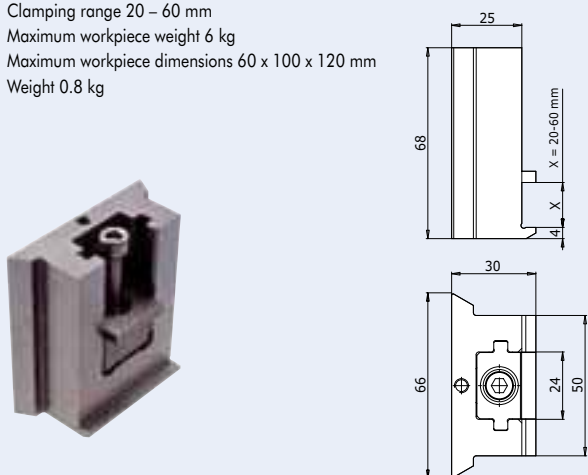

### ✓ Unimatic Vice 40-100 C 960 130

Workpiece carrier with guide for vertical parallel clamping.

- Functional height 100 mm
- Clamping range 40 – 100 mm
- Maximum workpiece weight 9 kg
- Maximum workpiece dimensions 100 x 100 x 120 mm
- Weight 1.2 kg

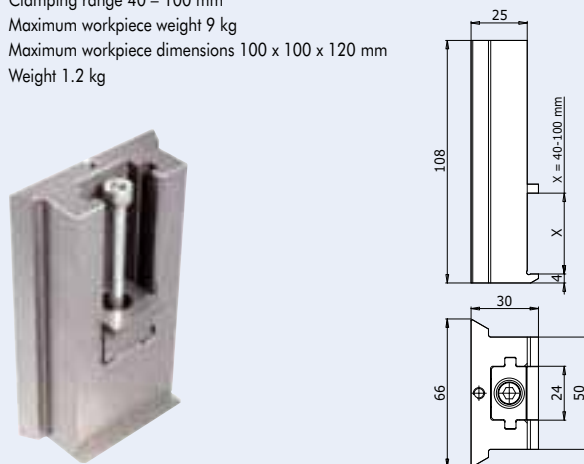

## THE HORIZONTAL CLAMPS (VICE)

and horizontal V-blocks require the clamping faces of the workpieces to have been machined parallel and rectangular in order to achieve secure clamping.

Tightening torque at the clamping screw:

- M6 max. 9 Nm
- M8 max. 20 Nm

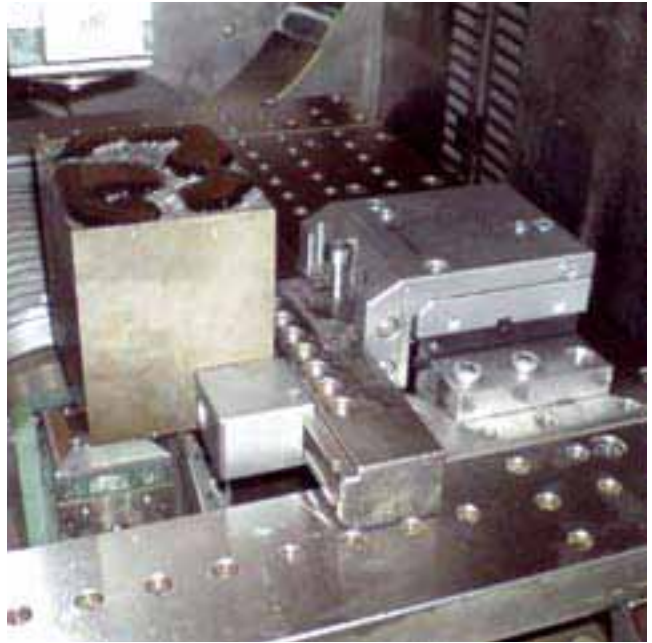

### ✓ Unimatic Vice 0-100 C 960 160

Workpiece holder with guide for horizontal parallel clamping.

- Functional height 50 mm
- Clamping range 0 - 100 mm
- Maximum workpiece weight 12 kg
- Maximum workpiece dimensions 100 x 120 x 130 mm
- Weight 2.0 kg

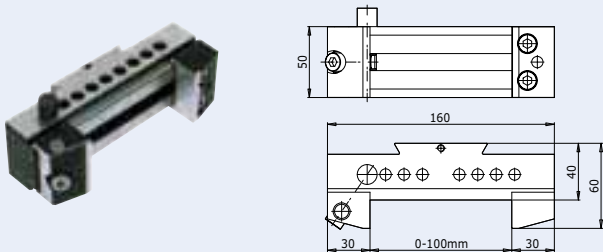

### ✓ Unimatic Vice 0-175 C 960 180

Workpiece holder with guide for horizontal parallel clamping.

- Functional height 30 mm
- Clamping range 0 - 175 mm
- Maximum workpiece weight 10 kg
- Maximum workpiece dimensions 100 x 120 x 160 mm
- Weight 2.,6 kg

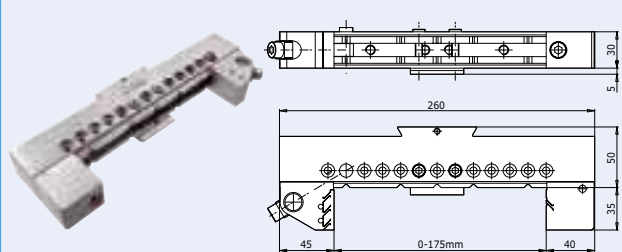

### Vice jaw set S 150 100

Jaw set for Mecavice B and Unimatic Vice with guide for horizontal parallel clamping.

- Functional height 30 mm
- Clamping depth jaw 18 mm
- Maximum workpiece weight 5 kg
- Weight 0.4 kg

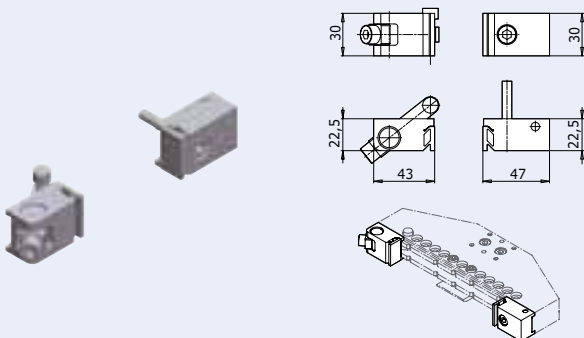

### Unimatic V-block 15-150 C 960 260

Workpiece holder for round parts.

- Functional height 35 mm
- Clamping range  $\varnothing$  15 - 150 mm
- Maximum workpiece weight 15 kg
- Maximum workpiece dimensions  $\varnothing$  150 x 100 mm
- Weight 1.8 kg

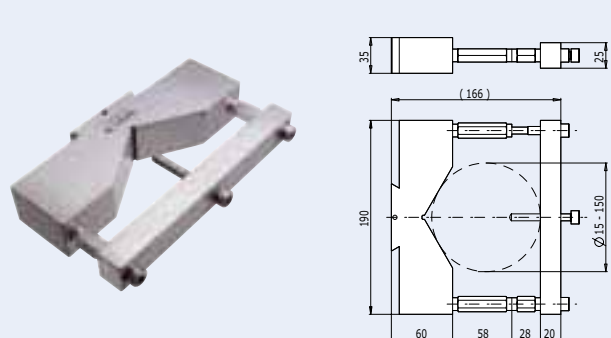

## ELECTRODE CLAMPING SYSTEMS

When machining electrodes, the integrated height adjustment facility of the Unimatic system offers particular advantages when setting the zero line.

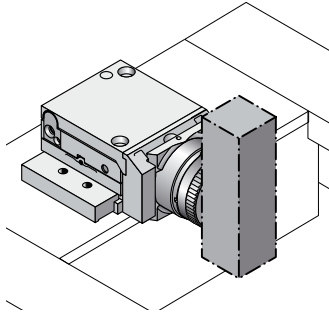

### Unimatic Adapter GPS 70 C 960 300

Adapter to Unimatic dovetail guide for the vertical adaptation of GPS 70 pallets in WEDM machines.

- Adaptation to GPS 70 pallets
- Weight 1.8 kg

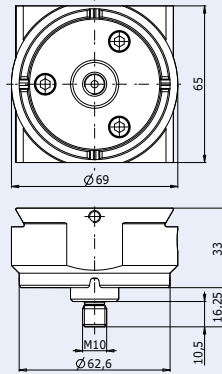

### Unimatic Adapter Macro C 960 330

Adapter to Unimatic dovetail guide for the vertical adaptation of Macro pallets in WEDM machines.

- Adaptation to Macro pallets
- Weight 2.2 kg

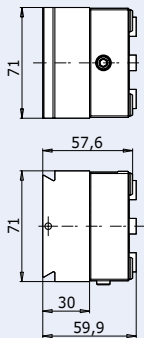

### Unimatic Guide vertical 150 C 960 350

The extended vertical guide allows Unimatic clamping elements to be clamped at raised positions. Application: machining of high workpieces or large electrodes for cavity sinking EDM.

- Functional height 150 mm
- Adaptation to all Unimatic clamping elements directly over dovetail
- Weight 3.2 kg

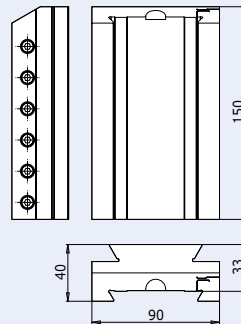

### ICS Adapter B GPS 70 C 463 140

Adapter to ICS B base elements for the vertical adaptation of GPS 70 pallets in WEDM machines.

- Functional height 23 mm axis-centre distance GPS 70 to interface ICS B
- Adaptation to GPS 70 pallets
- Weight 0.9 kg

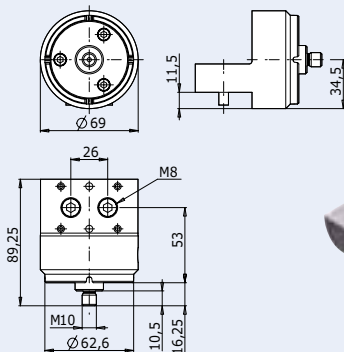

### ICS Adapter B Macro C 463 180

Adapter to ICS B base elements for the vertical adaptation of Macro pallets in WEDM machines.

- Functional height 23,5 mm axis-centre distance Macro to interface ICS B
- Adaptation to Macro pallets
- Weight 1.1 kg

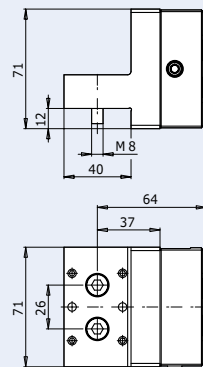

## SYSTEM ADAPTER

allows the user to employ the total diversity and strengths of all System 3R clamping elements on his machine and tooling configurations.

### ✓ ICS Adapter B Unimatic C 642 300

Adaptation of all Unimatic clamping elements on base elements with ICS B interface.

- Adaptation height 12 mm
- Adaptation to all Unimatic clamping elements
- Weight 1.1 kg

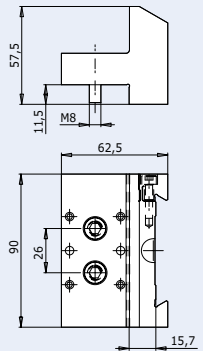

### ✓ Unimatic Adapter A, B or C

Adapter for ICS clamping elements; with Unimatic dovetail slide.

#### C 950 510

- ICS A
- Weight 0.3 kg

#### C 950 530

- ICS B
- Weight 0.4 kg

#### C 950 550

- ICS C
- Weight 0.6 kg



### ✓ Unimatic Adapter SuperVice/Macro WEDM C 950 480

Adapter for System 3R clamping elements with adaptation height 15 / 25 mm; with Unimatic dovetail slide.

- Functional height Unimatic: 40 mm / SuperVice/Macro: 15 / 25 mm
- Adaptation to Unimatic system C 950 150 or C 950 170 SuperVice/Macro to all clamping elements with functional height 15 / 25 mm
- Weight 1.3 kg

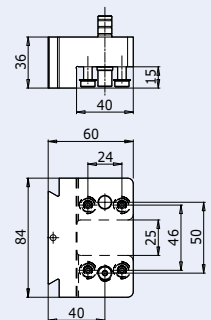

### ✓ Unimatic Adapter SuperVice/Macro WEDM C 950 490

Adapter for System 3R clamping elements with adaptation height 15 / 25 mm; with Unimatic dovetail slide.

- Functional height Unimatic: 40 mm / SuperVice/Macro: 15 / 25 mm
- Adaptation to Unimatic system C 950 150 or C 950 170 SuperVice/Macro to all clamping elements with functional height 15 / 25 mm
- Weight 1.3 kg

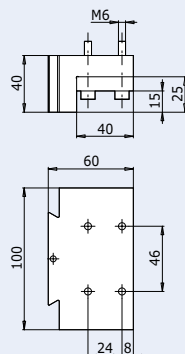
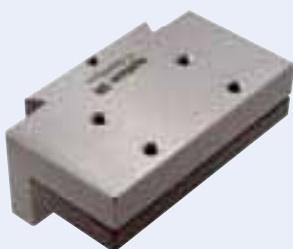

### Adapters

For upgrading machines fitted with ICS. The adapter gives access to the entire 3Ruler/3P/Macro range of WEDM accessories.

#### 3R-200.1J-62

- Length 140 mm
- Weight 2.3 kg



#### 3R-A6450

- Length 85 mm
- Weight 1.2 kg

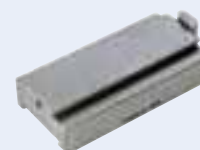

#### 3R-A6450-1

- Length 140 mm
- Weight 2 kg

### Set Unimatic Presetting (horizontal) S 206 200

Unimatic presetting station for horizontal clamping on Unimatic pallets. Inclusive support leg and pedestal with dial gauge.

- Functional height support leg = Zeroline 97 mm
- Weight 166 kg

consisting of:

|           |                                |    |
|-----------|--------------------------------|----|
| V 000 017 | Granite plate 100x500x800      | x1 |
| C 930 000 | Straight ruler                 | x1 |
| C 970 440 | Support leg 97                 | x1 |
| V 003 001 | Pedestal with dial gauge 0.002 | x1 |
| C 950 000 | Unimatic Chuck                 | x1 |
| C 950 012 | Unimatic Brackets              | x1 |
| C 970 400 | Unimatic Support base          | x1 |
| C 960 500 | Control unit                   | x1 |

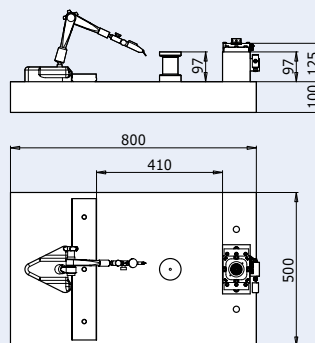

### Set Unimatic Presetting (horizontal/vertical) S 206 220

Unimatic presetting station for horizontal and vertical clamping on Unimatic pallets. Inclusive support leg and pedestal with dial gauge.

- Functional height support leg = Zeroline 162 mm
- Weight 190 kg

consisting of:

|           |                                |    |
|-----------|--------------------------------|----|
| V 000 017 | Granite plate 100x500x800      | x1 |
| C 930 000 | Straight ruler                 | x1 |
| C 848 100 | Support leg 162                | x1 |
| V 003 001 | Pedestal with dial gauge 0.002 | x1 |
| C 950 000 | Unimatic Chuck                 | x1 |
| C 950 012 | Unimatic Brackets              | x1 |
| C 950 050 | Unimatic Chuck                 | x1 |
| C 970 410 | Unimatic Support base          | x1 |
| C 970 420 | Unimatic Distance plate        | x1 |
| C 970 430 | Unimatic Angle plate           | x1 |
| C 960 500 | Control unit                   | x1 |

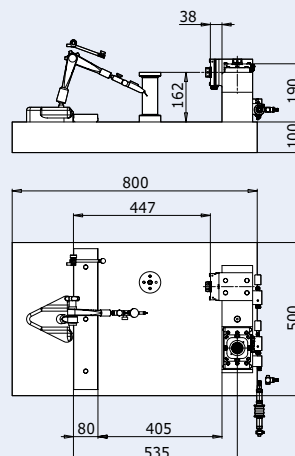

Presetting stations designed to user specifications on request.



**CUSTOMER SPECIFIC WEDM SOLUTIONS**

With the standard tooling elements of System 3R virtually all clamping tasks can be solved on WEDM machines in classical die and tooling production.

If wire-cut EDM is employed however in the precision manufacture of series parts, then apart from the pure clamping function, values such as the following are determined in addition to the layout and the design of the clamping means:

- Repeatability precision of the clamping of parts
- Expenditure of time for clamping and alignment
- Process safety in series production
- Multiple clamping
- etc

System 3R Schweiz AG (previously Mecatool AG) has stood for over 20 years for quality WEDM Tooling und WEDM System solutions.

The problems defined by our customers are challenges to us.



**CHANGE FRAMES**

are large palette systems which fit the dimensions of the WEDM machine table.

The sturdy construction enables even large workpieces to be clamped and to be changed with precise repeatability in the WEDM machine.

By adjustment of the clamping jaws to the current workpiece the expenditure on clamping and alignment can be significantly reduced.

System 3R change frames are available in versions for Unimatic or Macro WEDM machine table equipment.

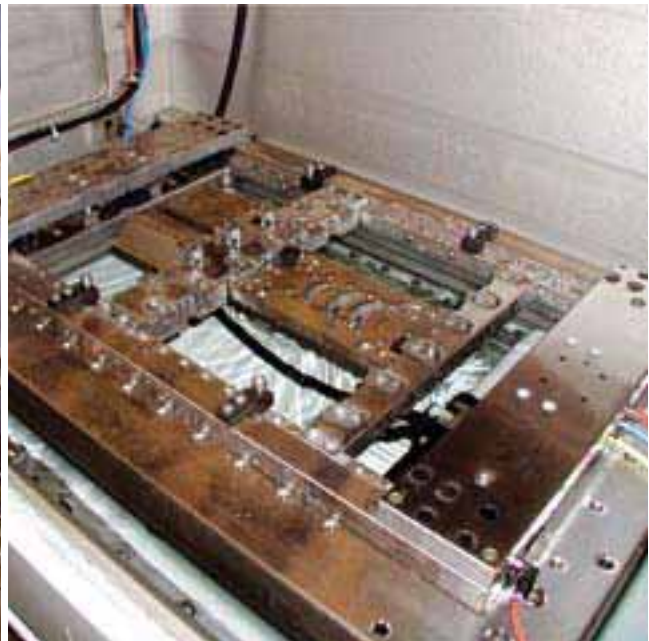
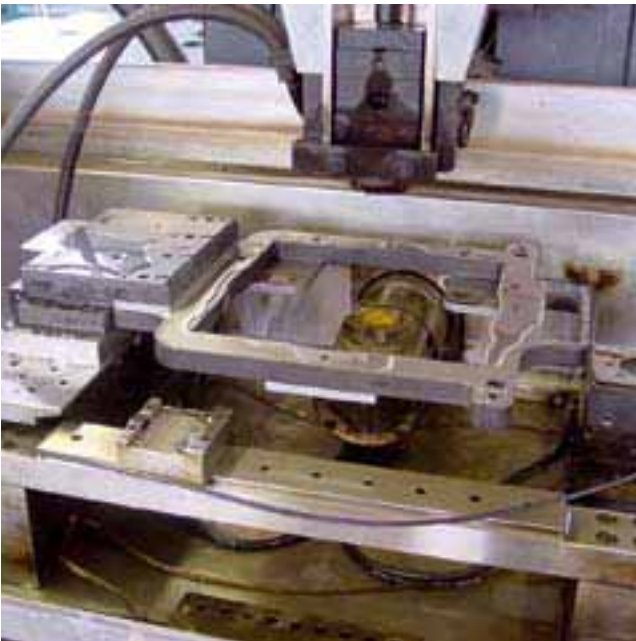
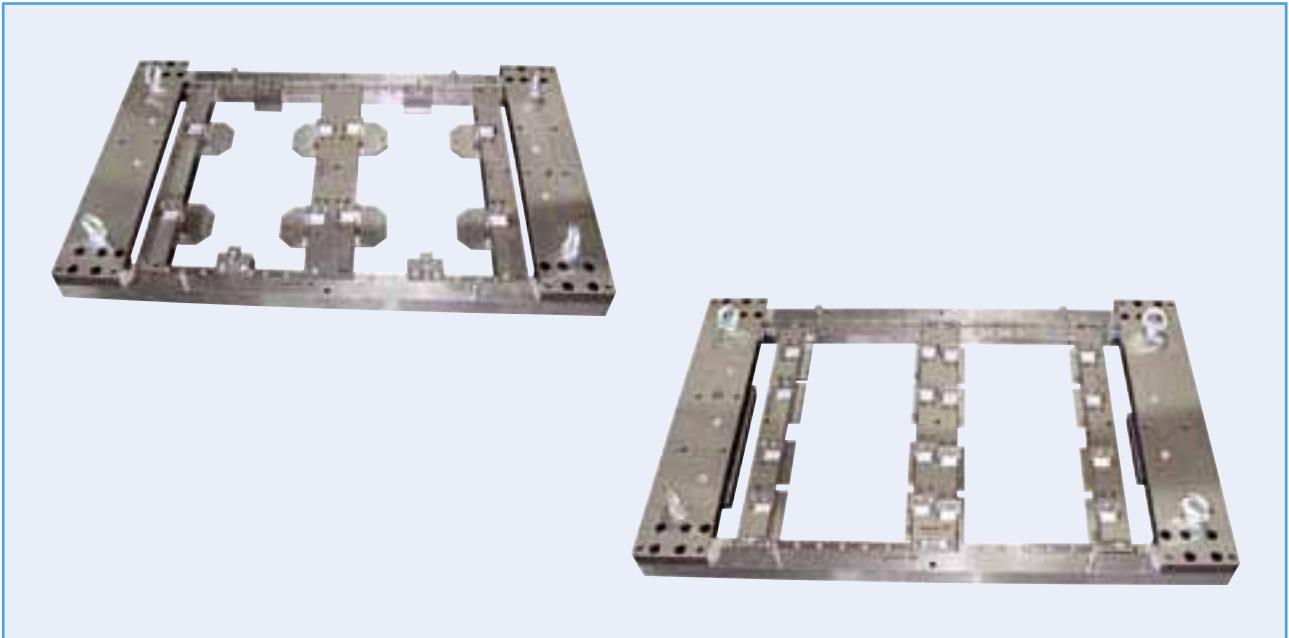
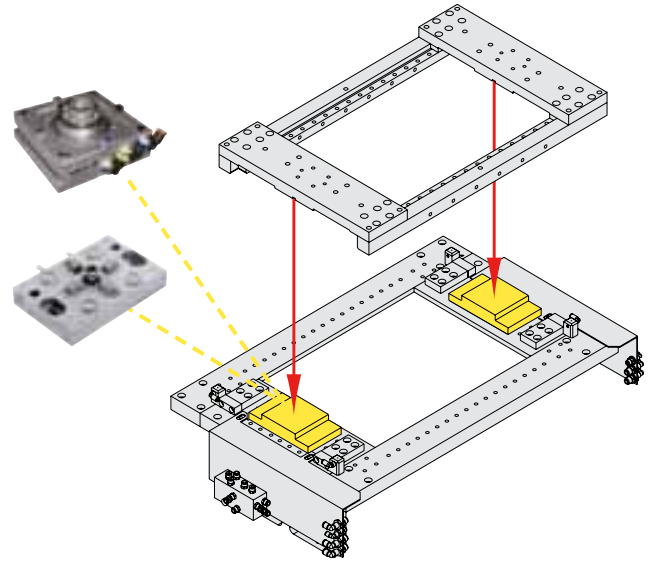



✓ **Clamp kit M6**  
**3R-230.1**

For clamping workpieces on rulers, etc.  
• Weight 1.8 kg



**Set ICS Double clamping M8**  
**C 860 000**



**Cleaning agent**  
**3R-N009**

Highly effective cleaning agent for EDM machines and accessories.  
• Supplied in one-litre packs



**Torque wrenches**

**3R-914-07**

• Torque 7 Nm

**3R-914-10L**

• Torque 7.8 Nm

**3R-914-10**

• Torque 10 Nm

**3R-914-15**

• Torque 15 Nm



**Bridge magnets**

**C 844 000**

• medium (8x12x55)

**C 844 100**

• strong (8x18x55)

**C 844 200**

• extra-strong (8x30x55)

**C 844 300**

• medium (8x12x30)



**Bridge magnets round**

**C 868 000**

• medium (Ø20)

**C 868 100**

• strong (Ø28)



**UTILISE EVERY HOUR OF THE DAY AND NIGHT!**

An automatic production cell can generate revenue round the clock, seven days a week. Why be satisfied with 40 productive machine-hours a week when the same machine can achieve over 100 additional hours a week? Use every hour of the day and night for production!

WorkPal, WorkPartner and WorkMaster - three "aces" which boost your productivity and sharpen your competitiveness.

And not least – they bring faster payback on the investments you made.



**WORKPAL COMPACT SERVO – MODEST DEMANDS, MAJOR BENEFITS**

WorkPal Compact Servo is a simple step into the world of automation. It's an easy-to-use, user-friendly pallet changer for automatic changing of pallets in wire EDM machines, for example.

A sliding door gives maximum access to the magazine, making it easier to manage the pallets. The extremely compact unit is simple to install. And what's more, WorkPal Compact Servo only needs minimal floor space.



**WORKPARTNER – CAN SERVE TWO MACHINES**

A compact unit for pallet changing, both on the machine table and in the machine spindle. WorkPartner is intended for applications in wire and die-sinking EDM machines or milling machines, for example.

Front loading makes it extremely user-friendly – open the doors and fill the magazines on the inside of the doors. In addition, the lower magazine shelf pulls out to make pallets and workpieces even easier to handle.

WorkPartner – capable of serving two machines at the same time. These could be machines of the same type and make, or machines with different machining technologies and of different makes.



**WORKMASTER – A MODULAR AUTOMATION CONCEPT**

WorkMaster is a versatile automation concept for a variety of applications in one or more milling machines and/or wire EDM machines, for instance. And changing can be done both in the machine spindle and on the machine table.

The changer unit is completely self-contained and can be adapted to “tailor-made” automation solutions with several types of magazine, as well as a number of options. One, two or three machines in the same production cell.

One clear advantage is the “open architecture” of the system. The customer chooses the machine (or machines) suited to the particular requirements of the business, and a WorkMaster is added.

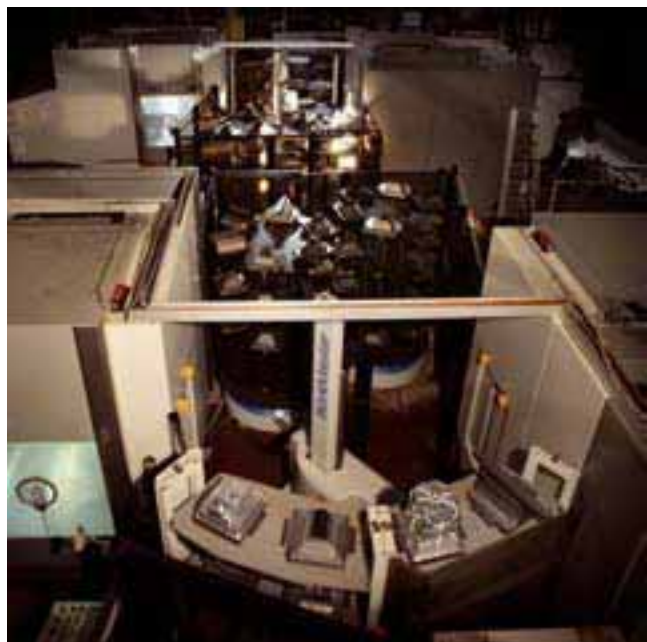
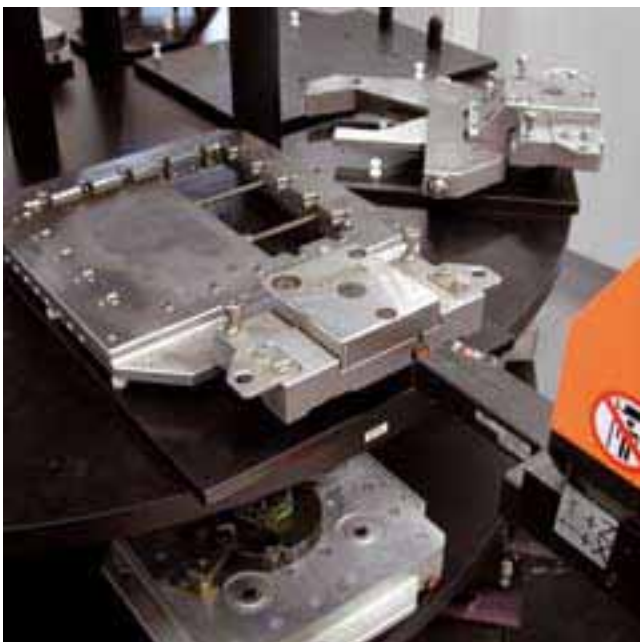

**Grip  
3R-W12-S**

For automatic changing of 3R-266.12., 3R-266.12HP and 3R-282.12HP



**Grip  
3R-WP1**

For automatic changing of 3R-206.10, 3R-622.5, 3R-622.6 or customer-made fixtures.

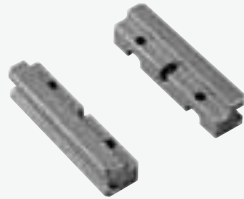

**Code carrier 4 mm  
3R-863.01-10**

With a pre-programmed unique identity.  
• Supplied in sets of 10



**Code carrier 2 mm  
3R-863.01-10M**

With a pre-programmed unique identity.  
• Supplied in sets of 10



**Unimatic code carrier  
fixture  
C 960 770**

• Weight 0,1 kg

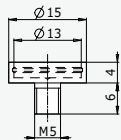

**Fixture with assembled  
code carrier  
C 960 800**

• Scope of delivery:  
C 960 770 Code tag fixture  
3R-863.01 Code tag



**Code carrier spacer  
D-40106**

For mounting code carrier 3R-863.01-10M on pallets



**Unimatic Locating pins  
C 960 780**

Locating pins to all Unimatic pallets, for System 3R gripper.  
• Set of 4 pieces  
• Weight 0,1 kg

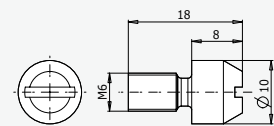

|                      |    |                       |        |                     |        |
|----------------------|----|-----------------------|--------|---------------------|--------|
| 3R-6.300-EHS16 ..... | 41 | 3R-261.1 .....        | 41     | 3R-605.2RS .....    | 27     |
| 3R-6.600-VHS .....   | 41 | 3R-262HP .....        | 14     | 3R-605.5RS .....    | 27     |
| 3R-60.360SA .....    | 11 | 3R-262.6 .....        | 32     | 3R-605.10 .....     | 11     |
| 3R-60.360X .....     | 11 | 3R-266.4 .....        | 14     | 3R-605.26 .....     | 11     |
| 3R-200.XJ.X .....    | 7  | 3R-266.5 .....        | 15     | 3R-605.27RS .....   | 11, 27 |
| 3R-200.1J-U .....    | 7  | 3R-266.12HP .....     | 15     | 3R-605-GE .....     | 11, 27 |
| 3R-200.1J-62 .....   | 70 | 3R-267.2 .....        | 16     | 3R-606.2 .....      | 40     |
| 3R-201.5 .....       | 11 | 3R-272HP .....        | 14     | 3R-611.4 .....      | 12     |
| 3R-201J .....        | 31 | 3R-282.12HP .....     | 15     | 3R-611.46 .....     | 12, 40 |
| 3R-202 .....         | 27 | 3R-292.1 .....        | 20     | 3R-611.60 .....     | 12     |
| 3R-203 .....         | 31 | 3R-292.2 .....        | 20     | 3R-613.4 .....      | 29     |
| 3R-203.6 .....       | 31 | 3R-292.3 .....        | 20     | 3R-613.6 .....      | 29     |
| 3R-204 .....         | 31 | 3R-292.3S .....       | 22     | 3R-622.2 .....      | 25     |
| 3R-205.2 .....       | 29 | 3R-292.6HP .....      | 20     | 3R-622.6 .....      | 25     |
| 3R-206.10 .....      | 40 | 3R-292.6S .....       | 21     | 3R-651.7E-P .....   | 28     |
| 3R-207.6 .....       | 29 | 3R-292.23 .....       | 23     | 3R-863.01-10 .....  | 77     |
| 3R-208.6 .....       | 30 | 3R-292.31 .....       | 20     | 3R-863.01-10M ..... | 77     |
| 3R-209B .....        | 33 | 3R-292.61HP .....     | 21     | 3R-901-10RS .....   | 41     |
| 3R-213.4 .....       | 30 | 3R-292.66HP .....     | 23     | 3R-914.07 .....     | 74     |
| 3R-215 .....         | 40 | 3R-293.3 .....        | 21     | 3R-914.10 .....     | 74     |
| 3R-216 .....         | 39 | 3R-293.33 .....       | 21     | 3R-914.10L .....    | 74     |
| 3R-216.6 .....       | 39 | 3R-293.6HP .....      | 21     | 3R-914.15 .....     | 74     |
| 3R-217-1 .....       | 26 | 3R-293.66HP .....     | 21     | 3R-A239 .....       | 36     |
| 3R-218S .....        | 37 | 3R-294 .....          | 23     | 3R-A239.1 .....     | 36     |
| 3R-220.3 .....       | 40 | 3R-294.1 .....        | 23, 36 | 3R-A6450 .....      | 70     |
| 3R-222.2 .....       | 27 | 3R-294.2 .....        | 23, 35 | 3R-A6450-1 .....    | 70     |
| 3R-223 .....         | 32 | 3R-294.3 .....        | 22     | 3R-N009 .....       | 74     |
| 3R-223.3 .....       | 32 | 3R-294.6 .....        | 23, 36 | 3R-SP6435 .....     | 26     |
| 3R-224 .....         | 32 | 3R-322/50E .....      | 30     | 3R-SSP014 .....     | 12     |
| 3R-225 .....         | 7  | 3R-402.1 .....        | 26     | 3R-SSP044 .....     | 12     |
| 3R-225.1 .....       | 7  | 3R-405.21RS .....     | 27     | 3R-W12-S .....      | 77     |
| 3R-225.2 .....       | 35 | 3R-406.9 .....        | 26     | 3R-WP1 .....        | 77     |
| 3R-226.4 .....       | 14 | 3R-422.2 .....        | 26     | 90825.01 .....      | 25     |
| 3R-226.6 .....       | 31 | 3R-466.40RS .....     | 26     | 90825.02 .....      | 25     |
| 3R-228J .....        | 39 | 3R-494-D10x50 .....   | 30     | C 170 XXX .....     | 49     |
| 3R-228S .....        | 39 | 3R-494-D12x50 .....   | 30     | C 187 900 .....     | 52     |
| 3R-228.1 .....       | 39 | 3R-494-D16x50 .....   | 30     | C 188 750 .....     | 52     |
| 3R-230.1 .....       | 74 | 3R-494-D22x50 .....   | 30     | C 300 050 .....     | 50     |
| 3R-232.8 .....       | 29 | 3R-494-D26x50 .....   | 30     | C 300 100 .....     | 50     |
| 3R-232S .....        | 16 | 3R-494-D32x50 .....   | 30     | C 350 100 .....     | 52     |
| 3R-237.1 .....       | 22 | 3R-494-D40x50 .....   | 30     | C 456 250 .....     | 49     |
| 3R-237.2 .....       | 22 | 3R-494-D50x50 .....   | 30     | C 456 350 .....     | 49     |
| 3R-239-XXX .....     | 33 | 3R-494-S12x50 .....   | 30     | C 456 450 .....     | 49     |
| 3R-239-XXX-D .....   | 34 | 3R-494-S22x50 .....   | 30     | C 456 600 .....     | 52     |
| 3R-239.1 .....       | 34 | 3R-494-S26x50 .....   | 30     | C 456 610 .....     | 52     |
| 3R-239.2 .....       | 34 | 3R-494-S32x50 .....   | 30     | C 456 650 .....     | 46     |
| 3R-239.3 .....       | 34 | 3R-494-S40x50 .....   | 30     | C 456 660 .....     | 46     |
| 3R-239.11 .....      | 35 | 3R-494-32x22x50 ..... | 30     | C 456 670 .....     | 46     |
| 3R-239.20 .....      | 35 | 3R-494-40x22x50 ..... | 30     | C 457 940 .....     | 16     |
| 3R-239.22 .....      | 36 | 3R-600.24-4RS .....   | 25     | C 457 960 .....     | 16     |
| 3R-239.24 .....      | 36 | 3R-601.7E-P .....     | 28     | C 457 980 .....     | 16     |
| 3R-242HP .....       | 16 | 3R-602 .....          | 32     | C 458 000 .....     | 47     |
| 3R-242S-1 .....      | 17 | 3R-602.4.1 .....      | 10     | C 458 010 .....     | 49     |
| 3R-242S-2 .....      | 17 | 3R-602.10 .....       | 10     | C 458 040 .....     | 47, 49 |
| 3R-242S-3 .....      | 17 | 3R-602.10HP .....     | 10     | C 458 060 .....     | 47, 49 |
| 3R-242S-4 .....      | 17 | 3R-602.12HP .....     | 10     | C 458 080 .....     | 47, 49 |
| 3R-242.82HP .....    | 17 | 3R-602.26 .....       | 10     | C 463 140 .....     | 69     |
| 3R-243.2-1 .....     | 32 | 3R-602.27 .....       | 10     | C 463 180 .....     | 69     |
| 3R-252.1 .....       | 27 | 3R-602.27-1 .....     | 25     | C 550 500 .....     | 51     |
| 3R-261 .....         | 41 | 3R-605.1RS .....      | 11     | C 550 650 .....     | 60     |

|                |        |                |        |                |    |
|----------------|--------|----------------|--------|----------------|----|
| C 550 670..... | 61     | C 950 100..... | 56     | S 150 500..... | 43 |
| C 550 900..... | 51     | C 950 120..... | 56     | S 150 550..... | 43 |
| C 551 300..... | 51     | C 950 130..... | 56     | S 150 560..... | 43 |
| C 551 700..... | 51     | C 950 140..... | 56     | S 190 520..... | 58 |
| C 552 100..... | 51     | C 950 150..... | 55     | S 190 900..... | 58 |
| C 552 300..... | 62     | C 950 170..... | 55     | S 206 200..... | 71 |
| C 552 400..... | 62     | C 950 180..... | 56     | S 206 220..... | 71 |
| C 552 500..... | 62     | C 950 190..... | 56     | S 206 301..... | 55 |
| C 552 600..... | 46     | C 950 280..... | 16     | S 206 4XX..... | 45 |
| C 552 610..... | 46     | C 950 290..... | 47, 49 | X 227 820..... | 39 |
| C 552 620..... | 46     | C 950 470..... | 15     |                |    |
| C 552 630..... | 44     | C 950 480..... | 70     |                |    |
| C 552 640..... | 44     | C 950 490..... | 70     |                |    |
| C 557 XXX..... | 45     | C 950 510..... | 70     |                |    |
| C 558 XXX..... | 45     | C 950 530..... | 70     |                |    |
| C 573 550..... | 63     | C 950 550..... | 70     |                |    |
| C 574 150..... | 63     | C 951 100..... | 56     |                |    |
| C 574 550..... | 65     | C 951 120..... | 56     |                |    |
| C 575 050..... | 65     | C 951 130..... | 56     |                |    |
| C 575 550..... | 65     | C 951 140..... | 56     |                |    |
| C 575 600..... | 65     | C 951 150..... | 55     |                |    |
| C 577 200..... | 61     | C 951 170..... | 55     |                |    |
| C 577 250..... | 60     | C 951 180..... | 56     |                |    |
| C 577 350..... | 63     | C 951 190..... | 56     |                |    |
| C 577 370..... | 63     | C 960 010..... | 66     |                |    |
| C 596 050..... | 64     | C 960 030..... | 66     |                |    |
| C 596 650..... | 64     | C 960 050..... | 66     |                |    |
| C 597 250..... | 64     | C 960 060..... | 66     |                |    |
| C 597 550..... | 64     | C 960 100..... | 67     |                |    |
| C 597 560..... | 46     | C 960 110..... | 67     |                |    |
| C 599 450..... | 60     | C 960 120..... | 67     |                |    |
| C 619 660..... | 61     | C 960 130..... | 67     |                |    |
| C 619 670..... | 22, 61 | C 960 160..... | 68     |                |    |
| C 619 680..... | 22     | C 960 180..... | 68     |                |    |
| C 641 900..... | 61     | C 960 260..... | 68     |                |    |
| C 642 050..... | 64     | C 960 300..... | 69     |                |    |
| C 642 150..... | 65     | C 960 330..... | 69     |                |    |
| C 642 160..... | 65     | C 960 350..... | 69     |                |    |
| C 642 300..... | 70     | C 960 430..... | 58     |                |    |
| C 665 600..... | 44     | C 960 440..... | 47     |                |    |
| C 665 700..... | 44     | C 960 450..... | 58     |                |    |
| C 665 720..... | 44     | C 960 500..... | 58     |                |    |
| C 665 900..... | 44     | C 960 710..... | 58     |                |    |
| C 666 020..... | 43     | C 960 770..... | 77     |                |    |
| C 666 040..... | 43     | C 960 780..... | 77     |                |    |
| C 844 000..... | 74     | C 960 800..... | 77     |                |    |
| C 844 100..... | 74     | D-40106.....   | 77     |                |    |
| C 844 200..... | 74     | K-30266.....   | 12     |                |    |
| C 844 300..... | 74     | N 150 050..... | 50     |                |    |
| C 860 000..... | 74     | N 460 000..... | 50     |                |    |
| C 868 000..... | 74     | N 460 100..... | 50     |                |    |
| C 868 100..... | 74     | N 460 300..... | 50     |                |    |
| C 909 000..... | 52     | N 460 700..... | 50     |                |    |
| C 909 020..... | 52     | S 112 050..... | 55     |                |    |
| C 909 060..... | 52     | S 112 060..... | 55     |                |    |
| C 909 010..... | 52     | S 149 500..... | 57     |                |    |
| C 950 000..... | 54     | S 149 900..... | 46     |                |    |
| C 950 070..... | 54     | S 150 000..... | 46     |                |    |
| C 950 090..... | 47     | S 150 100..... | 63, 68 |                |    |
| C 950 0XX..... | 55     | S 150 310..... | 46     |                |    |