

Ионекс

Тольятти: (8482) 25-82-40, (8482) 25-82-85, (927) 775-49-65, (906) 128-12-68, tlt@ionexedm.ru
Москва: (499) 782-61-17, (916) 627-56-24, (926) 300-12-42, msh@ionexedm.ru
Томск: (3822) 23-16-80, (909) 543-16-80, toms@ionexedm.ru

www.ionexedm.ru

CLAMPING TOOLS WEDM

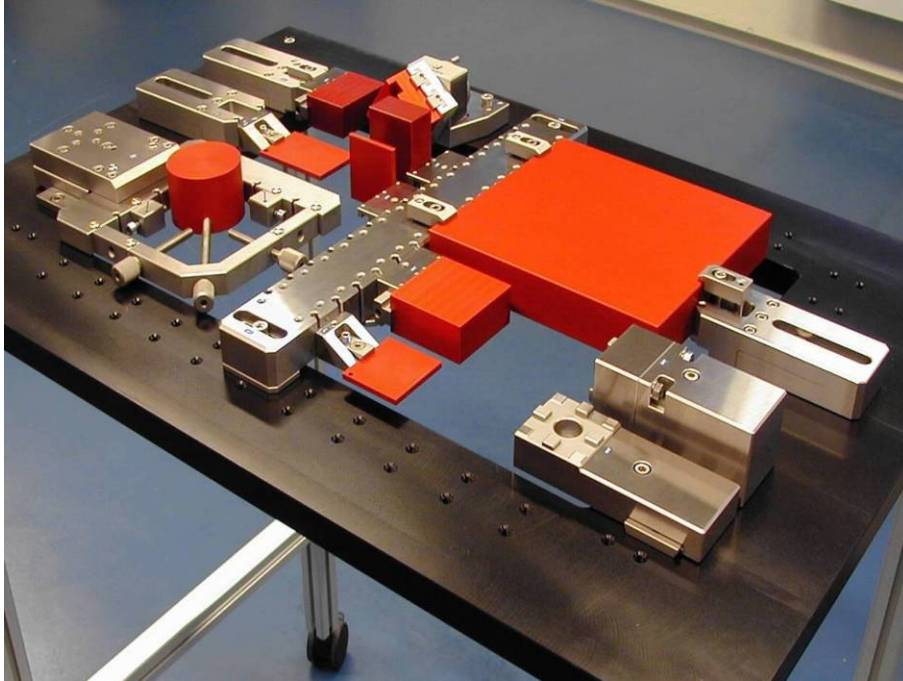

REFERENCE RULERS

We offer two types of reference rulers.

All rulers are grounded within tolerance -0.01 , flatness of surface up to $0.001/100$
Rulers length and pitch of assembling grooves for screws M8 is made according to the type of machine.

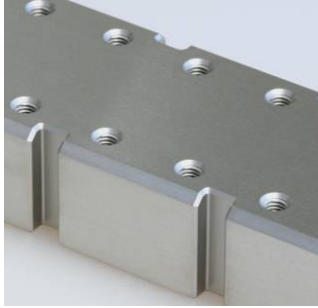

standard - D

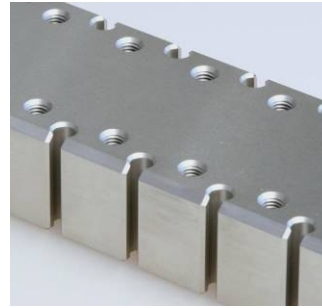

LOGIC - L

System **LOGIC** - for further extension of clamping possibilities with high-speed components.



Reference ruler type D



Reference ruler type L

VERTICALLY ADJUSTABLE RULERS WZ

Rulers for easy setting of workpiece plane.
Construction makes longitudinal and cross setting of plane possible.
Range of vertical setting is $\pm 0,25\text{mm}$.



WZ150L

Adjustable ruler $Z\pm 0.25\text{mm}$
System **LOGIC** for further extension of clamping possibilities
Dimensions: 150x60x30 mm, groove for screw M8
Maximum workpiece weight: 50kg



WZ220L

Adjustable ruler $Z\pm 0.25\text{mm}$
System **LOGIC** for further extension of clamping possibilities
Dimensions: 220x66x30 mm, groove for screw M8
Maximum workpiece weight: 60kg

EXAMPLES OF WORKPIECES FIXATION



Workpieces fixation by means of 4 rulers WZ150L

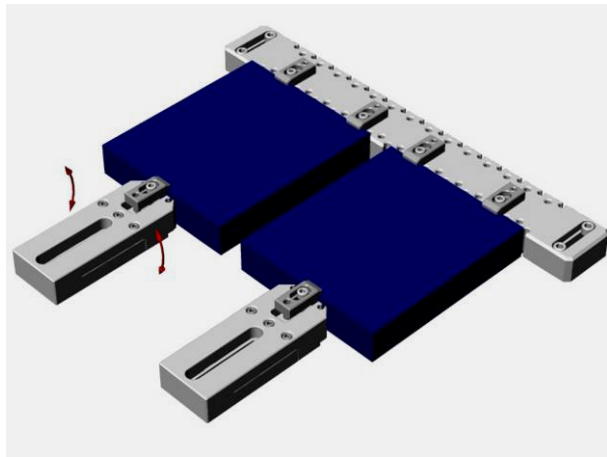

Workpieces fixation by means of 2 supporters WZ150L and a reference ruler

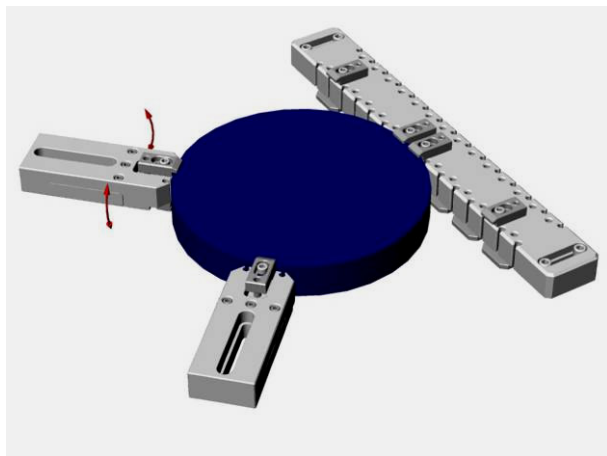

Round workpiece fixation by means of 2 supporters WZ150L and a reference ruler

ACCESSORIES FOR REFERENCE RULERS

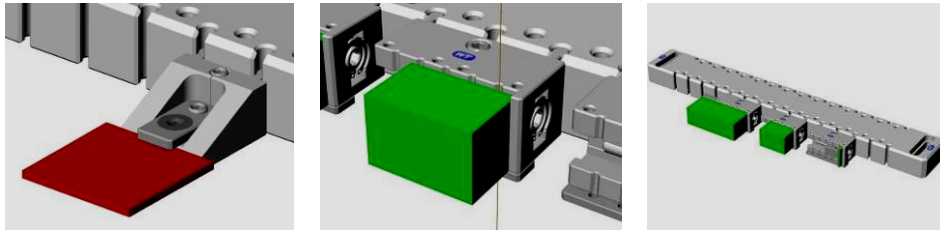

WSD25L

Segment for thin workpieces
Mounting on reference rulers type **L**
Dimensions: 35x40x20mm



WS60L

Vice for small workpieces
Range of clamping: 0-100mm
Mounting on reference rulers type **L**
Dimensions: 60x35x30mm

ACCESSORIES FOR SUPPORTERS WZ

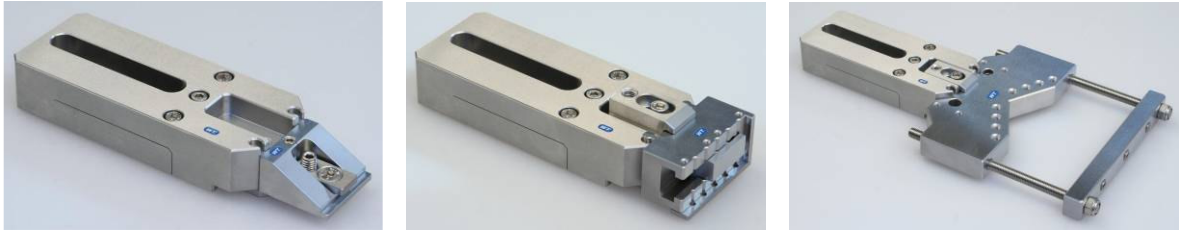

WSD34LZ

Segment for thin workpieces
Mounting on supporters WZ150L or WZ220L
Dimensions: 42x40x20mm



WS60LZ

Vice for small workpieces
Range of clamping: 0-100mm
Mounting on supporters WZ150L or WZ220L
Dimensions: 60x35x30mm

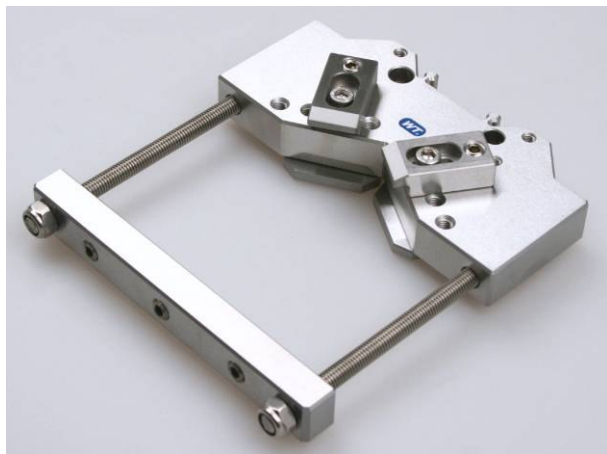

WNP120L

Prism for round or rectangular workpieces
Range of clamping: $d10-120\text{mm}$, 120×120
Mounting on supporters WZ150L, WZ220L
Dimensions: $86 \times 150 \times 19\text{mm}$



WPR200

Prism for small round workpieces
Range of clamping: $d3-20\text{mm}$
Mounting on supporters WZ150L, WZ220L
Dimensions: $200 \times 36 \times 28\text{mm}$

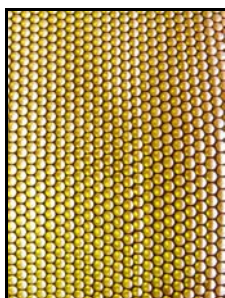
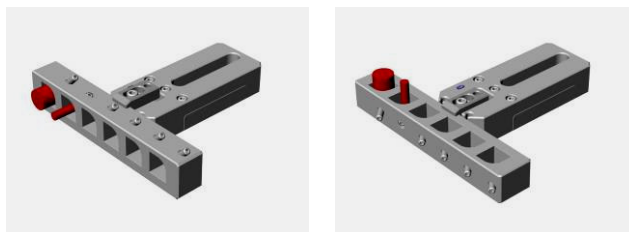

Ионекс

Тольятти: (8482) 25-82-40, (8482) 25-82-85, (927) 775-49-65, (906) 128-12-68, tlt@ionexedm.ru
Москва: (499) 782-61-17, (916) 627-56-24, (926) 300-12-42, msk@ionexedm.ru
Томск: (3822) 23-16-80, (909) 543-16-80, tomsk@ionexedm.ru

www.ionexedm.ru

CLAMPING SYSTEM WEDM 3R



WL75-M8

Reference element sequence 200.xJ-X
Dimensions: L=75mm, mounting holes for screws M8



WL150-M8

Reference element sequence 200.xJ-X
Dimensions: L=150mm, mounting holes for screws M8

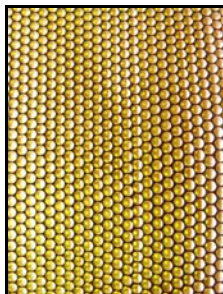

Ионекс

Тольятти: (8482) 25-82-40, (8482) 25-82-85, (927) 775-49-65, (906) 128-12-68, tlt@ionexedm.ru
Москва: (499) 782-61-17, (916) 627-56-24, (926) 300-12-42, msk@ionexedm.ru
Томск: (3822) 23-16-80, (909) 543-16-80, tmsk@ionexedm.ru

www.ionexedm.ru

ACCESSORIES FOR CLAMPING SYSTEM WEDM 3R

Clamping panels enable quick aligning in three axes.
Workpiece can be preset outside the machine on a stone plate.
Clamp all the unit into the machine and start machining without waiting time.



WND10

Adjustable clamping panel
Possible aligning in three axes $\pm 1^\circ$
Max weight: 10kg
Dimensions: 130x85x39mm



WND15HP

Adjustable clamping panel
Possible aligning in three axes $\pm 1^\circ$
Max weight: 15kg
Dimensions: 140x90x48mm



WS150 HP

Vice for larger workpieces
Range of clamping: 0-150mm
Max weight: 15kg
Mounting on WND15HP
Dimensions: 205x100x25mm



WNP175

Prism for round or rectangular workpieces
Range of clamping: d_{10} -175mm, 175x175
Max weight: 15kg
Mounting on WND15HP
Dimensions: 205x128x25mm

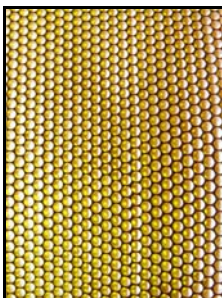

Ионекс

Тольятти: (8482) 25-82-40, (8482) 25-82-85, (927) 775-49-65, (906) 128-12-68, tlt@ionexedm.ru

Москва: (499) 782-61-17, (916) 627-56-24, (926) 300-12-42, msk@ionexedm.ru

Томск: (3822) 23-16-80, (909) 543-16-80, tomsk@ionexedm.ru

www.ionexedm.ru



WND10 SET

Set for small workpieces of round or rectangular profile
Max workpiece dimension: d120mm, 120x120mm
Max workpiece weight: 10kg



WNDP15HP SET

Set for workpieces of round or rectangular profile
Max workpiece dimension: d175mm, 175x175mm
Max workpiece weight: 15kg



WDP56 SET

Dividing appliance for workpieces of round and rectangular profile
Range of clamping: d2-20mm, vice 0-100mm
Mounting on WND10, WND15HP,
or directly on the machine table.
Angle adjustment with the aid of dividing disc by 1°
or sine ruler.

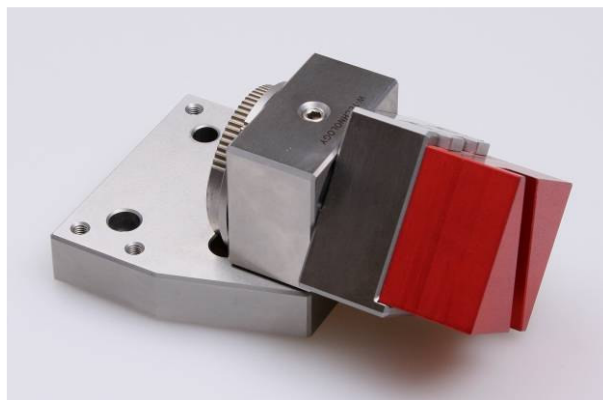

WDP56

Dividing appliance - vice
Range of clamping: 0-100mm



WDP56-ER32

Dividing appliance – collet clamp ER32
Range of clamping: d2-20mm



WRS56-ITS

Vice for workpiece aligning in two axes with angle setting.
Range of clamping: 0-100mm, angle setting 0-360°
Mounting: for clamping system ITS or MACRO
Dimensions: 56x56x94 mm



WS5494 SET

Vice for reference rulers sequence 3R-239-xxx

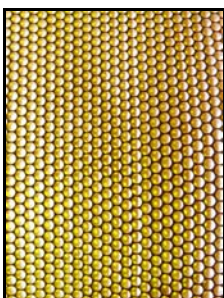
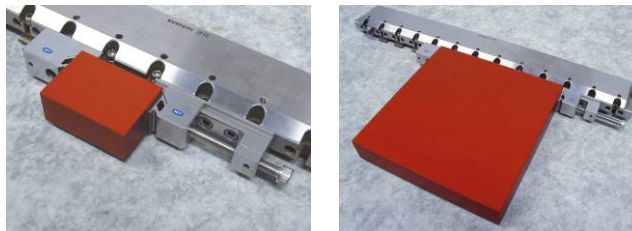

Ионекс

Тольятти: (8482) 25-82-40, (8482) 25-82-85, (927) 775-49-65, (906) 128-12-68, tlt@ionexedm.ru

Москва: (499) 782-61-17, (916) 627-56-24, (926) 300-12-42, mzk@ionexedm.ru

Томск: (3822) 23-16-80, (909) 543-16-80, tomsk@ionexedm.ru

www.ionexedm.ru

TOOL UNITS FOR WIRE EDM MACHINES

CHARMILLES



WL330D SET

Basic set for ROBOFIL 240
Dimensions: grooves for screws M8, distance 290mm
Max workpiece weight: 200kg



WL330L SET

Basic set for ROBOFIL 240
System **LOGIC** for further extension of clamping possibilities
Dimensions: grooves for screws M8, distance 290mm
Max workpiece weight: 200kg



WL454D SET

Basic set for ROBOFIL 390
Dimensions: grooves for screws M8, distance 414mm
Max workpiece weight: 200kg



WL454L SET

Basic set for ROBOFIL 390
System **LOGIC** for further extension of clamping possibilities
Dimensions: grooves for screws M8, distance 414mm
Max workpiece weight: 200kg



WL460D SET

Basic set for ROBOFIL 440
Dimensions: grooves for screws M8, distance 420mm
Max workpiece weight: 200kg



WL460L SET

Basic set for ROBOFIL 440
System **LOGIC** for further extension of clamping possibilities
Dimensions: grooves for screws M8, distance 420mm
Max workpiece weight: 200kg

AGIE



WL410D SET

Basic set for AGIE series 2
Dimensions: grooves for screws M8, distance 370mm
Max workpiece weight: 200kg



WL410L SET

Basic set for AGIE series 2
System **LOGIC** for further extension of clamping possibilities
Dimensions: grooves for screws M8, distance 370mm
Max workpiece weight: 200kg



WL510D SET

Basic set for AGIE series 3
Dimensions: grooves for screws M8, distance 470mm
Max workpiece weight: 200kg



WL510L SET

Basic set for AGIE series 3
System **LOGIC** for further extension of clamping possibilities
Dimensions: grooves for screws M8, distance 470mm
Max workpiece weight: 200kg



Ионекс

Тольятти: (8482) 25-82-40, (8482) 25-82-85, (927) 775-49-65, (906) 128-12-68, tlt@ionexedm.ru

Москва: (499) 782-61-17, (916) 627-56-24, (926) 300-12-42, msk@ionexedm.ru

Томск: (3822) 23-16-80, (909) 543-16-80, tomsk@ionexedm.ru

www.ionexedm.ru

SODIC / FANUC



WL490D SET

Basic set for SODIC AQ325 / FANUC a1i
Dimensions: grooves for screws M8, distance 450mm
Max workpiece weight: 200kg



WL490L SET

Basic set for SODIC AQ325 / FANUC a1i
System **LOGIC** for further extension of clamping possibilities
Dimensions: grooves for screws M8, distance 450mm
Max workpiece weight: 200kg

MITSUBISHI



WL370D SET

Basic set for MITSUBISHI FA10-S,-V
Dimensions: grooves for screws M8, distance 330mm
Max workpiece weight: 200kg



WL370L SET

Basic set for MITSUBISHI FA10-S,-V
System **LOGIC** for further extension of clamping possibilities
Dimensions: grooves for screws M8, distance 330mm
Max workpiece weight: 200kg



WL470D SET

Basic set for MITSUBISHI FA20-S,-V
Dimensions: grooves for screws M8, distance 430mm
Max workpiece weight: 200kg



WL470L SET

Basic set for MITSUBISHI FA20-S,-V
System **LOGIC** for further extension of clamping possibilities
Dimensions: grooves for screws M8, distance 430mm
Max workpiece weight: 200kg

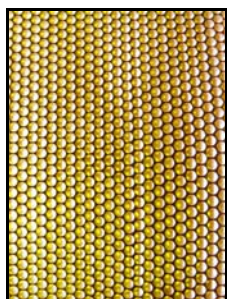

Ионекс

Тольятти: (8482) 25-82-40, (8482) 25-82-85, (927) 775-49-65, (906) 128-12-68, tlt@ionexedm.ru

Москва: (499) 782-61-17, (916) 627-56-24, (926) 300-12-42, mск@ionexedm.ru

Томск: (3822) 23-16-80, (909) 543-16-80, tomsк@ionexedm.ru

www.ionexedm.ru